

AMERON CAT. NO.	BRACKET ARM ALUMINUM	MOUNTING HEIGHT	POLE HEIGHT
6-C1-23-F8	8'	29'-9"	26'-3"
6-C1-28-F8	8'	34'-9"	31'-3"

NOTES:

- BRACKET ARM, MOUNTING AND POLE HEIGHTS TO BE SHOWN ON PLANS.
- 3'-0" DIA. CIRCULAR FOUNDATION MAY BE USED IN PLACE OF 2'-6" SQ. FOUNDATION.
- ALL BASES SHALL BE POURED TO 4" BELOW SIDEWALK GRADE.
- THE AREA AROUND ALL STANDARDS SHALL BE FORMED AND POURED WITH GROUT TO EXTEND 6" ON EACH SIDE AND BACK OF STANDARD AND FROM BACK OF CURB TO FRONT OF STANDARD. GROUT SHALL BE POURED FROM TOP OF BASE TO SIDEWALK GRADE. GROUT SHALL CONSIST OF 2 PARTS SAND AND 1 PART CEMENT.
- EACH POLE SHALL HAVE A PULL BOX. SEE STD-204-L
- FUSE HOLDER IN ADJACENT PULL BOX, SEE STD-205-L
- ALL THREADED CONNECTIONS SHALL HAVE PRE-APPROVED ANTI-SEIZE COMPOUND.
- SEE POLE LEVELING DETAIL TO THE RIGHT.
- FOR POLE WIRING , SEE CNB STD-205-L.

MOUNTING HEIGHT

POLE HEIGHT

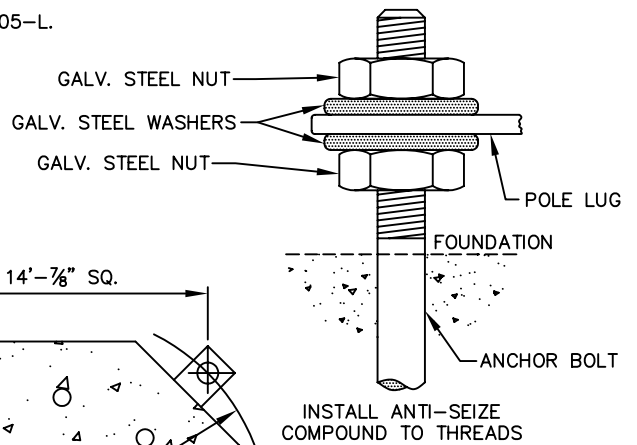

LEVELING DETAIL

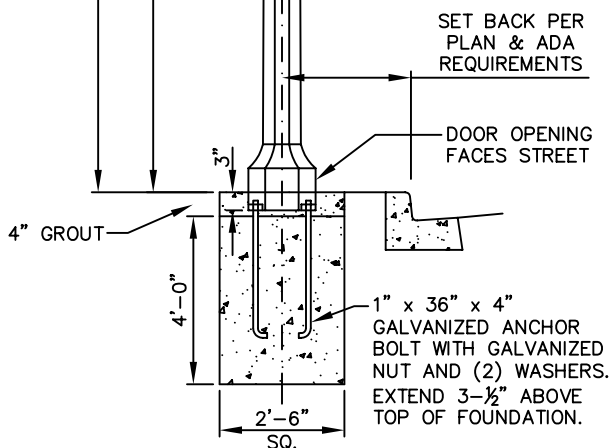

ELEVATION

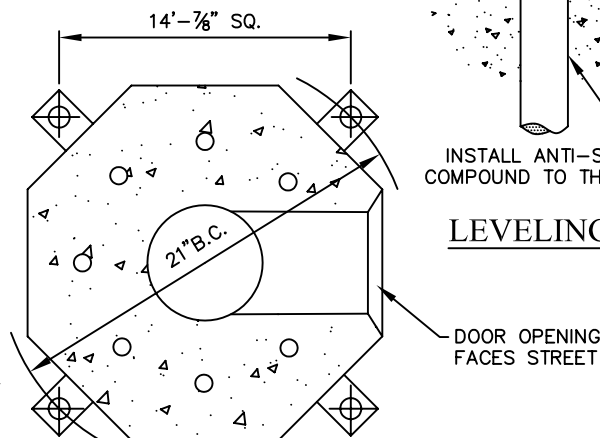

BASE DETAIL

CITY OF NEWPORT BEACH
PUBLIC WORKS DEPARTMENT

LIGHTING STANDARD
TYPE II

APPROVED:

PUBLIC WORKS DIRECTOR

RCE NO. 36106

Drawn: M. Elias

Scale: N.T.S.

Date: Jan. 2004

F:\USERS\PBW\Shared\CAD STD\STD Details\2003 Std\STD SrLight

DRAWING NO.

STD-201-L