



# CITY OF NEWPORT BEACH

## COMMUNITY DEVELOPMENT DEPARTMENT

### BUILDING DIVISION

100 Civic Center Drive | P.O. Box 1768 | Newport Beach, CA 92658-8915  
[www.newportbeachca.gov](http://www.newportbeachca.gov) | (949) 644-3200

## GRADING/DRAINAGE PLAN REVIEW COMMENTS

Project Description:

**Project Address:**

**Plan Check No.:**

Permit App. Date:

Permit App. Expires:

CY Cut/Fill:

Permit Valuation:

Adjusted Valuation:

Architect/Engineer:

Phone:

Applicant/Contact:

Phone:

**Plan Check Engineer:**

**Phone:**

**Engineer email:**

1<sup>st</sup> Review: (date)

2<sup>nd</sup> Review:  
*Italic comments*

3<sup>rd</sup> Review:  
**By Appointment**

**The project plans were reviewed for compliance with the following codes and standards:**

2022 CRC; 2022 CBC; 2022 CPC; 2022 CEC; 2022 CMC; 2022 California Energy Code; 2022 California Green Building Standards Code (CG); & Chapter 15 of the Newport Beach Municipal Code (NBMC)

**The code section references are from the 2022 CBC, unless otherwise stated.**

- **TO EXPEDITE PROJECT APPROVAL:** Please provide a written response indicating how and where each comment was resolved on the plans.
- Resubmit all previously reviewed plans, updated plans and supporting documents with each subsequent review.
- **AFTER 2<sup>nd</sup> PLAN REVIEW:** Please call the plan check engineer listed above to schedule a plan review appointment, to expedite project approval.
- For clarification of any plan review comment, please call the plan check engineer listed above.
- Plan review status is available online at [https://css.newportbeachca.gov/EnerGov\\_Prod/SelfService#/home](https://css.newportbeachca.gov/EnerGov_Prod/SelfService#/home). Project status is also available by speaking with a permit technician at 949-718-1888 during business hours.

## **GENERAL**

1. Please note on plan: "ISSUANCE OF A BUILDING PERMIT BY THE CITY OF NEWPORT BEACH DOES NOT RELIEVE APPLICANTS OF THE LEGAL REQUIREMENTS TO OBSERVE COVENANTS, CONDITIONS AND RESTRICTIONS WHICH MAY BE RECORDED AGAINST THE PROPERTY OR TO OBTAIN PLANS. YOU SHOULD CONTACT YOUR COMMUNITY ASSOCIATIONS PRIOR TO COMMENCEMENT OF ANY CONSTRUCTION AUTHORIZED BY THIS PERMIT."
2. Please note on plan: "PRIOR TO PERFORMING ANY WORK IN THE CITY RIGHT-OF-WAY AN ENCROACHMENT PERMIT MUST BE OBTAINED FROM THE PUBLIC WORKS DEPARTMENT."
3. Include the following on all plan sheets in the title block:
  - a. Site address,
  - b. Plan preparer's name, address and telephone number,
  - c. Property owner's name, address and telephone number.
4. All permits related to the proposed project shall be issued at the same time, or separate plans and plan review will be required for items not issued with this review. Provide additional permit worksheets for the following:
  - a. Accessory structures, detached patio covers and trellises,
  - b. Walls/retaining walls within 3 feet of property lines
  - c. Masonry or concrete fences over 3.5 ft high greater than 3 feet from property lines.
  - d. Retaining walls over 4 ft high from the bottom of the foundation to the top of the wall greater than 3 feet from property lines.
5. Obtain plan review approval from the following:
  - a. Planning Department,
  - b. Public Works Department.
6. Final drawings which will be approved for permit issuance shall be signed by the respective design professionals (electronic signature is acceptable). This comment will remain up to and include at the time of permit issuance.

## **SURVEY CORRECTIONS:**

7. Provide a site survey, stamped and signed by a State Licensed Land Surveyor or authorized Civil Engineer (License Number below 33,966). Provide note on plan, "Surveyor or engineer shall permanently monument property corners or offsets before starting grading."
8. Show north point and scale.
9. Show location and description of all corner monuments.
10. Show and identify all property lines. Dimension length and specify bearing.
11. Show driveway, curb and gutter, and all existing site improvements (structures, walls, planters, stairs, etc.).
12. Identify all finish surface materials.
13. Provide a legend for all symbols used.
14. Locate all trees in public-right-of-way facing or within 20 feet of the subject property; power poles; utility boxes, etc.
15. Show center line of street and dimension width or ½ width.
16. Specify benchmark used for survey.
17. Provide elevations at the following locations:
  - a. All property corners.

- b. Around existing structure(s) at corners, including corners at jogs of exterior walls.
- c. At interior finish floor elevations.
- d. At bottom of all site walls. Indicate wall height.
- e. At bottom of elevated planters. Indicate planter height.
- f. At maximum spacing of 25' along the length and width of the property on all sides of an existing structure.
- g. Elevation contours for sloping sites every one-foot elevation change.
- h. Three elevations (min.) equally spaced in the side yard of adjacent properties.
- i. Three elevations along the flow line in gutter and alley adjacent to site.

### **GRADING CORRECTIONS:**

- 18. For projects on a slope, adjacent to a slope, with a basement, or project sites which require remedial grading, soils engineer shall review and approve the grading plan, foundation plan, and shoring plan to verify that the design is consistent with the geotechnical report recommendations. Soils engineer shall stamp these plans with a review stamp asserting compliance with geotechnical report recommendations. This comment will remain up to and include at the time of permit issuance.
- 19. Provide property address on grading plan.
- 20. Show vicinity map indicating site location.
- 21. Show name, address, and telephone number of property owner, plan preparer, and geotechnical engineer.
- 22. Show north arrow, plan scale, and legend.
- 23. Identify ALL property lines by clearly indicating their location.
- 24. Clearly identify the scope of work. Distinguish between existing hardscape/landscape and proposed hardscape/landscape improvements.
- 25. Show locations of all existing buildings, structures, pools, fences, retaining walls, etc. Show grade elevation on both sides of wall and specify top of wall elevation.
- 26. Show accurate contours (or spot elevations) indicating the topography of the existing ground. Show locations of all existing slopes on and adjacent to the property.
- 27. **Site Grading:** CBC Section 1804.4. The ground immediately adjacent to the foundation shall be sloped away from the building at a slope of not less than 1 unit vertical in 20 units horizontal (5%-percent slope) for a minimum distance of 10 feet, measured perpendicular to the face of the wall. If physical obstructions or lot lines prohibit 10-feet of horizontal distance, a 5-percent slope shall be provided to an approved alternative method of diverting water away from the foundation. Swales used for this purpose shall be sloped not less than 2-percent where located within 10-feet from the foundation. For impervious surfaces 2% slope minimum.
- 28. **The top of any exterior foundation** shall extend above the elevation of the street gutter at point of discharge, or the inlet of an approved drainage device a minimum of 12 inches plus 2 percent. Drainage shall conform to Section 15.10.120 of the NBMC. (NBMC 15.10.060, **CBC 1808.7.4**)
- 29. All drainage water from a newly graded or a regraded site shall be directed from a privately owned property directly to the public drainage system to meet **CBC Section 1805.4.3** and conform to Section 15.10.120 (E) of the NBMC.
- 30. For non-residential projects and multi-dwelling projects, specify on permit application the cost of construction of all drainage devices and drainage improvements.
- 31. Obtain a private drainage easement to drain water over adjacent land not owned by the permittee. Easement must be recorded with the County Recorder's Office.
- 32. Provide a drainage design that prevents entrance of drainage water from the street/alley onto property (CBC 1804.4.1).

33. Clearly show elevation of adjacent properties and the distance from property lines to adjacent structures.
34. Comply with the minimum slope at the following areas (NBMC 15.10.120 F):
 

Earth	5.0%	10'-feet perpendicular distance from foundation.
Concrete	2.0%	10'-feet perpendicular distance from foundation.
Concrete	0.5%	
Concrete gutter in paved area	0.2%	
Asphalt	1.0%	
Subterranean drainage pipe	1.0%	
35. Show finish grades by spot elevations to indicate proper drainage in all areas. Use arrows to indicate direction of drainage.
36. Provide a drainage swale at side yard. Draw a section through swale. Swale shall comply with CBC 1804.4 where applicable.
37. Show top of drain elevations and drain invert elevations.
38. Show downspout locations and connection to drain line or discharge location.
39. Design the drainage system to retain concentrated and surface sheet flow water from dry-weather run off and minor rain events within the site. (NBMC 15.10.120)
  - a. Sheet flow through lawn areas and/or area drains connect to a minimum 15' long French drain in crushed rock bed wrapped with filter cloth as shown in Figure A on last page provided:
    - i. Site meets infiltration feasibility criteria as set forth in Table 2.7 of the Technical Guidance Document (TGD) and,
    - ii. One French drain per maximum of 2,000 sf of impervious area having appropriate hydraulic source controls.
    - iii. For sites not suitable for infiltration per Table 2.7, considerations should be given to feasibility of harvest and use per Appendix X of TGD, and if not feasible, bioretention and finally biofiltration to treat design capture volume prior to discharge.
    - iv. Locate French drain away from foundations and slopes.
  - b. Alternate: Provide hydrology calculations and design retention system to retain  $\frac{3}{4}$ " of rain over 24 hr.
  - c. Provide the following note on the plans, "Any changes to the hardscape / landscape must be indicated on a revised precise grading plan, approved by the City, and may trigger a Water Quality Management Plan (WQMP) consistent with the model WQMP, Exhibit 7.II."
40. Provide a trench drain at bottom of driveway as shown in Figure B on last page. (Exception: When driveway is less than 10' long and no other site drainage flows through driveway)
41. Provide specifications for drain lines. Specify diameter 4" (min.) and type of material. The following drain line materials may be used:
  - a. ABS, SDR 35
  - b. ABS, SCHEDULE 40
  - c. PVC, SDR 35
  - d. PVC, Schedule 40
  - e. ADS 3000 with PE glued joints
42. Use CPC Table 1103.2 to determine required site drain pipe size (diameter) and slope.
43. The minimum distance between exterior finish grade and bottom of treated sill plate shall be as follows: (CRC R317.1, **CBC 2304.12.1.2**)
  - a. 3" to concrete finish
  - b. 8" to soil

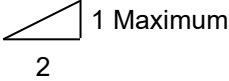
44. Specify volume of cut and fill in cubic yards.
45. Design drainage to ensure water does not drain over the top edge of any slopes. (NBMC 15.10.120) Provide a berm at top of slope. Draw a section through berm. Berm to be 12" high and slopes towards the pad
- 
46. Show top and toe of all slopes and indicate slope ratio.
- 
47. List the pertinent "Grading Notes" on plans.
48. Where grading is proposed on adjacent property not owned by the permittee, a separate permit is required for that portion under the adjacent address.
49. Show locations and details of subdrain system(s) and outlet for retaining walls on grading plan when subdrain is required by soils report. Subdrain shall be piped separately from site drainage or invert in French drain shall be higher than the invert elevation of the nearest drain.
50. Provide erosion and siltation control plans.
51. Provide a section showing required grading cut and proximity to property line.
52. Provide building or structure setbacks from top and bottom of slope as shown in **CBC, Fig. 1808.7.1**. For descending slopes less than 12 feet in height, minimum setback from competent slope face material shall be 4 feet.
53. Top and toe of slope to be setback from the property line per NBMC 15.10.110 (B), Fig. 1.
54. Provide two copies of soils and foundation investigation report by a registered civil engineer.
55. Soils report shall address the potential of soft or compressible or collapsible or liquefiable soils (Site Classes D, E and F), and recommend mitigation method if they exist.
56. Soils report shall present seismic site coefficients with supporting documentation.
57. List soils report recommendations on grading plan.
58. Commercial projects: A Grading bond is required for this project. Submit propose grading bond to permit tech supervisor at the Permit Center. The bond shall be review by Building Division staff and approve by the City Attorney prior to the issuance of a grading permit. (NBMC 15.10.080)
59. Construction with a basement, or excavation closer than 3 ft. to property line, or when the distance from edge of excavation to the property line is less than the depth of excavation, require the following:
- a. Notification of intent to excavate required: Use the City standard form '30-DAY NOTICE OF INTENT TO EXCAVATE' to notify adjacent property owners by certified mail 30 days prior to starting excavation or shoring. City standard form can be obtained at: <http://www.newportbeachca.gov/home/showdocument?id=17395>. Proof of certified delivery is required at the time of permit issuance."
  - b. Add the following notes on the grading plan:
    - i. "Cal-OSHA permit is required for excavations deeper than 5' and for shoring and/or underpinning."
    - ii. "Continuous Special Inspection, per section 1705.6, shall be performed by the geotechnical engineer during shoring and excavation operations and during removal of shoring."
  - c. Shoring plans and calculations are required by a registered civil engineer. Provide a description of the process for installing shoring, construction of basement walls, and removal of shoring.

- d. Site profiles along property lines are required to indicate existing grade on both sides of property lines, proposed grade(s), depth of over excavation, top of retaining wall, bottom of retaining wall, depth of retaining wall footings.
- e. Cross-sections are required at various locations showing excavation details drawn to scale with dimensions. Show all buildings and masonry walls on adjacent property within a distance equal to the depth of the proposed excavation. Excavation, shoring, proposed retaining wall(s) with their subterranean drainage and their footings shall all be entirely within the proposed project's property lines.
- f. Slot-cutting method of excavation, provide supporting computations by a registered geotechnical engineer and a drawing showing the location of slots, their width and sequence of slot cuts. Slot cut to be at least 36" away from any property lines and not exceed 5 feet in depth.
- g. Temporary continuous vertical cut, with a distance from the edge of excavation to the property line of less than the depth of excavation, need computations with a satisfactory cut stability factor of safety, supported by laboratory data in a soils report. The total height of vertical cut must include the height of proposed retaining wall with its footing and shear key. Excavation to comply with CBC 1804.1 and 1803.5.7.
- h. Geotechnical engineer shall stamp and sign shoring plan(s), certifying design complies with the soils report's recommendations.
- i. Add the following note on the shoring drawing, "Licensed surveyor to provide horizontal and vertical monitoring of shoring and improvements on adjacent properties and submit results with a report to the shoring design engineer and to the building inspector on a daily basis during excavation and shoring and weekly basis thereafter. Where dewatering is required, monitoring shall continue until dewatering is stopped."
- j. If bottom of excavation is at or below historical ground water level, submit a dewatering plan and computations by a registered geotechnical engineer.
- k. Provide additional geotechnical information necessary for dewatering system design, soils report must include the following:
  - i. Borings for soils investigation to extend a minimum of 20 ft. below bottom of proposed excavation.
  - ii. Provide sieve analysis and permeability value for each soil formation layer to a depth of 20 ft. below bottom of excavation.
- l. Non-cantilevered retaining walls must be shored until the bracing element(s) is in place. Provide a design for wall shoring.
- m. Cantilever shoring supporting hardscape improvements, foundations or swimming pool within a distance of less than half the shoring height shall be designed based on at rest earth pressure.
- n. Depth of embedment of shoring caissons shall not be less than that outlined in CBC Section 1807.3.2.
- o. Sheet piles are not permitted for shoring due to potential damage to adjacent properties.
- p. Steel soldier pile used as permanent support component of retaining wall shall be protected from earth with 3" concrete cover. Alternate methods of protecting steel flange from corrosion require an application for "Alternate Materials and Methods" with supporting documents and method of protecting material from damage during lagging installation.
- q. If crushed rock is used to support temporary shoring steel soldier pile, specify method of compaction for gravel fill and method of grouting hole created when steel pile is removed.

### **DEWATERING SYSTEM CORRECTIONS:**

60. Provide the following information on dewatering drawings:
  - a. Well or well point locations.

- b. Pipe system layout (including valve locations).
  - c. Primary power source. If a generator is used for primary power supply, write a note on drawings stating maximum noise level from proposed generator not to exceed 50 dba on adjoining property.
  - d. Back-up power supply (if any).
  - e. Location of desanding tank.
  - f. Location of property lines and excavation limits.
  - g. Depth of wells or well points (reference to sea level or other datum).
  - h. Diameter of borehole.
  - i. The type of filter media used around wells or well points. Provide sieve analysis graph.
  - j. Size of wellscreen openings (slots) and location of screened portion of well or well point.
  - k. Soil permeability. Dewatering is required during excavation, soil investigation to include boring(s) to a depth of 20' below bottom of proposed excavation for sieve analysis to determine soils permeability.
  - l. Discharge termination point.
  - m. Water meter to measure flow.
  - n. Anticipated draw-down elevation.
  - o. Depth of deepest excavation.
  - p. Method of well removal and abandonment.
61. If a well point system is used, provide noise calculation using ARI method to verify noise level from pump not to exceed 50 dba at adjacent property.
62. Public Works approval is required for discharge into storm drain or public way.
63. Provide evidence of approval from State Regional Water Quality Control Board for disposal of ground water.

**WATER QUALITY CORRECTIONS:**

64. If area of construction site is one or more acres, obtain a general construction NPDES Storm water permit from the State Water Resources Control Board. Tel. (909) 782-4130.
65. This project falls into category circled below. Prepare a Water Quality Management Plan (WQMP) consistent with the model WQMP, Exhibit 7.II (<http://media.ocgov.com/gov/pw/watersheds/documents/wqmp/>).

**A. PRIORITY PROJECTS (Model WQMP Table 7.II-2)**

- i. New development projects that create 10,000 square feet or more of impervious surface. This category includes commercial, industrial, residential housing subdivisions, mixed-use, and public projects on private or public property that falls under the planning and building authority or the Permittees.
- ii. Automotive repair shops. This applies to facilities that are categorized in any one of the following Standard Industrial Classification (SIC) codes 5013, 5014, 7532-7534, and 7536-7539.
- iii. Restaurant where the land area of development is 5,000 square feet or more including parking area;
- iv. Hillside development 5,000 square feet or more which is located on areas with known erosive soil condition or where natural slope is 25% or more;
- v. Impervious surface of 2,500 square feet or more located within or directly adjacent to (within 200 ft.) or discharging directly to receiving water within environmentally sensitive areas (San Diego Creek, upper and lower Newport Bay, Buck Gully, Los Trancos, Little Corona del Mar Beach, Crystal Cove State Beach).
- vi. Parking lot area of 5,000 square feet or more or including associated drive aisle, and potentially exposed to urban stormwater runoff. A parking lot is defined as a land area

or facility for the temporary parking or storage of motor vehicles used personally, for business, or for commerce.

- vii. Street, roads, highways, and freeways with paved surfaces of 5,000 square feet or more used for transportation of automobiles, trucks, motorcycles, and other vehicles.
- viii. All significant redevelopment projects consisting of addition or replacement of 5,000 or more square feet of impervious surface on an already developed site. Redevelopment does not include routine maintenance activities that are conducted to maintain original line and grade, hydraulic capacity, original purpose of the facility, or emergency redevelopment activity required to protect public health and safety.
  - a. If the redevelopment results in the addition or replacement of less than 50 percent of the impervious area on-site and the existing development was not subject to WQMP requirement, the numeric sizing criteria discussed in Section 7.II-20 of Model WQMP only applies to the addition or replacement area. If the addition or replacement is 50 percent or more of the impervious area, the Project WQMP requirements apply to the entire development.
- ix. Retail gasoline outlets of 5,000 square feet or more or those with a projected Average Daily Traffic (ADT) of 100 or more vehicles per day.

**B. NON PRIORITY PROJECTS (Model WQMP, 7.11-1.3)**

- i. Require issuance of non-residential plumbing permit for pipelines conveying hazardous materials (e.g. gasoline).
- ii. Require discretionary action that will include a precise plan of development (Typically requested by the Planning Division of Community Development Department).

**SWPPP CORRECTIONS:**

- 66. For projects one acre or more, submit SWPPP Report prepared by a Qualified SWPPP Developer (QSD) (<http://cfpub.epa.gov/npdes/stormwater/swppp.cfm>).
- 67. Cal Green Nonresidential Mandatory Measures: SWPPP Report is required for newly constructed projects and additions, which disturbed less than one acre.

**ADDITIONAL CORRECTIONS:**

- 68. See Water Quality Management Plan (WQMP) - Plan Review Comments and Guidelines for Preparing WQMP Report (<http://www.newportbeachca.gov/Modules/ShowDocument.aspx?documentid=3232>) (<http://www.newportbeachca.gov/Modules/ShowDocument.aspx?documentid=18026>).
- 69. See drawings for additional corrections.



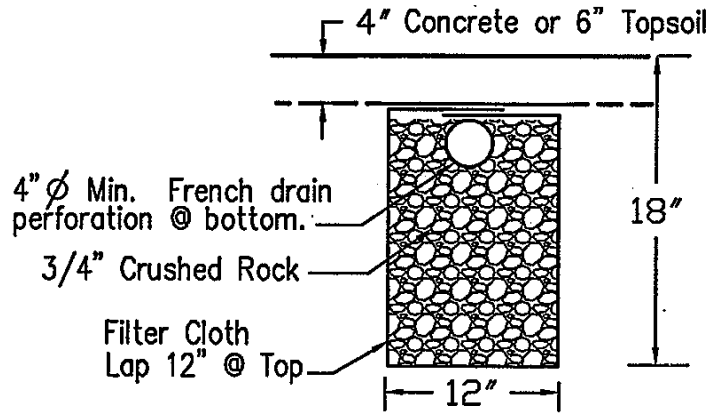

**PERFORATED DRAIN/TRENCH DETAIL**

*Figure A*

DIMENSIONS DETERMINED BY GRATE FRAME DIMENSIONS. USE FRAME AS A FORM

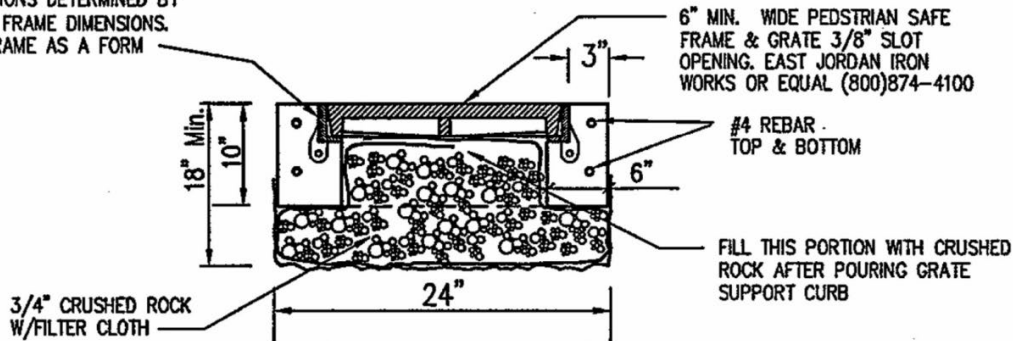

**SECTION E-E**

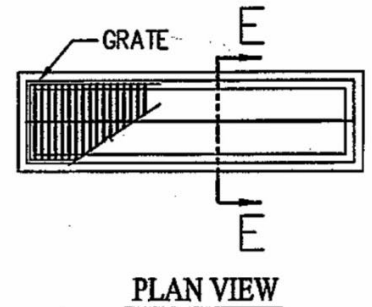

**PLAN VIEW**

- a- Dig a 24" wide X 18" minimum depth trench
- b- Place filter cloth in the trench. Lap 12" @ top
- c- Fill bottom of the trench with 3/4" crushed rock.
- d- Form and pour perimeter concrete curb.
- e- Fill the rest of the trench with crushed rock to 4" from top of trench.

**BOTTOMLESS TRENCH DRAIN**

*Figure B*