



CITY OF NEWPORT BEACH

COMMUNITY DEVELOPMENT DEPARTMENT

LIFE SAFETY SERVICES

GUIDELINES AND STANDARDS

GUIDELINE F.04 - Private Hydrants and Sprinkler Supply Line Underground Piping

F.04.1 PURPOSE

The purpose of this guideline is to provide information and requirements for the design and installation of private hydrants and/or sprinkler supply underground piping in accordance with the provisions of the California Fire Code (CFC), California Building Code (CBC), NFPA 24, NFPA 13, NFPA 13R, and locally adopted amendments to these codes.

F.04.2 SCOPE

This guideline shall apply to all private hydrants and sprinkler supply line underground piping.

F.04.3 PROCEDURE

PLAN SUBMITTAL AND PERMITS

- The installing contractor must have the appropriate license to design and install private Fire Hydrant and underground fire protection supply lines in accordance with the California Code of Regulations Title 16, Division 8, Chapter 9, Article 4 of the Professional and Vocational Regulations, State Contractors License Board, Classifications.
 - Authority cited; Sections 7008 and 7059, Business and Professions Code.
- Plans for all private underground piping for private hydrants and/or sprinkler supply line(s) shall be submitted to the Newport Beach Permit Center for review and approval prior to approval of civil engineering plans.
- To determine the number of plans required for submittal, contact the Newport Beach Permit Center at (949) 718-1888; minimum size of plan is 18" x 24".

- Plans shall be legible, scaled to nationally recognized standards, and printed as blue line or black line drawing. Pen and ink plans or pen and ink changes to blue line plans are not allowed.
- A current flow test data report (dated within six months) shall accompany the plans. Contact the Newport Beach Municipal Operations Department (MOD) at (949) 644-3410.

TITLE PAGE INFORMATION

- Applicable codes and standards used for the system design.
- Project location including the full legal address of the facility, and building number(s).
- All plans shall list the name of the contractor(s), telephone number, address, and appropriate California contractor's license number and classification.
- Newport Beach Fire Department underground notes, verbatim. See pages 4 - 6 of this guideline.

ADDITIONAL REQUIRED INFORMATION

- A. Location of public mains.
- B. Location of all public hydrants within 300' of the project site.
- C. Location of all valves. Specify the type for each - i.e. post indicator valve (PIV), key gate valve, system control valve, double detector check (DDC), outside stem & yoke (OS&Y), etc.
- D. PIVs or other approved indication valves, shall be located a minimum of 40' from the building served. Where it is impractical to locate control valves(s) 40' from the building served, they may be permitted to be located closer utilizing one of the following methods:
 1. Approved wall mount indicating valves, provided they are located on blank walls (i.e. no openings within 15' on either side of the valve and no openings above, clear to the roof).
 2. Approved indicating valves may be placed in valve rooms accessible only from the exterior. An approved sign shall be provided at the door.

3. Approved indicating valves may be placed on exterior risers provided they are located on blank walls (i.e. no openings within 15' on either side of the valve and no openings above, clear to the roof).
- E. Post indicator valves shall be set so that the top of post will be 36" above final grade. Show elevation detail on plans.
 - F. Pipe size, class, and type: specify lined or unlined, if applicable.
 - G. Show thrust block locations, or specify the means of restraint. If providing thrust blocks, City of Newport Beach Public Works Standard 510-L-A (Thrust Blocks) shall be shown on plans (copy attached).
 - H. Location of the Fire Department Connection (FDC). FDCs shall be on the address side of the building and located a minimum of 30 feet from beginning of the radius for the driveway approach; arranged so they are located immediately adjacent to the approved fire department access road so that hose lines can be readily and conveniently attached to the inlets without interference from nearby objects including buildings, fence, posts, or other fire department connections.
 - I. The FDCs shall be located no more than 100' from a public hydrant. The FDC may be located within 100' of a private hydrant if the FDC is connected to the fire sprinkler system by a dedicated pipe that connects on the system side of the sprinkler system check valve.
 - J. The FDC shall be a listed assembly. The FDC shall contain a minimum of two 2½" inlets. An additional inlet shall be provided for every 250 gpm over a design hose stream allowance of 500 gpm.
 - K. The FDC vertical piping shall be ductile iron, steel pipe is not permitted.
 - L. The FDC should be located not less than 18" and not more than 4' above the level of the adjacent grade or access level. Show elevation detail on plans.
 - M. Large private service mains shall have post indicating type sectional control valves at appropriate points in order to permit isolation of the system in the event of a break or during repair or extension. Note: A large system is one with over five connections, including hydrants, to the main.
 - N. Only ductile iron pipe shall be used under buildings or as an approved listed assembly consistent with chapter 80 NFPA 24. Pipe under buildings shall terminate a maximum of 18" from the exterior wall and six inches above finished floor. A minimum of 2" clearance (interstitial space) shall be provided where the pipe passes through the floor wall.

- O. Fire hydrants shall be installed in accordance with City of Newport Beach Public Works Standard 500-L (Wet Barrel Fire Hydrant)*. Standard shall be provided on plans (copy attached).

**Note: Public Works preference is Star Pipe Products - Stargrip Series 3000 and Series 4000 for joint restraint and full body MJ C110 T fittings and C110 90° flanged fittings. Contact the Utilities Division at (949) 644-3011 for approval of other manufacturers' products prior to installation.*

- P. List make and manufacturer of all fittings and restraint and scan manufacturers cut sheets for these onto plan.
- Q. The attached "NOTES FOR UNDERGROUND PIPING FOR PRIVATE HYDRANTS AND SPRINKLERS" shall be placed, verbatim, on all underground plans.

NEWPORT BEACH LIFE SAFETY SERVICES NOTES FOR UNDERGROUND PIPING FOR PRIVATE HYDRANTS & SPRINKLERS

1. Prior to installation, all required permits shall be obtained from the Building Division.
2. Inspections are required: (1) prior to pouring thrust blocks, (2) for hydrostatic testing, and (3) for flush. Call City of Newport Beach automated inspection request line at (949) 644-3255 or go online at:
<http://newportbeachca.gov/government/departments/community-development/building-division/building-permit-inspection-request-status>.
3. Installation, inspection, and testing shall conform to NFPA 13 and NFPA 24.
4. Double check back flow prevention valve assembly required. Contact the Newport Beach Public Works Department at (949) 644-3311.
5. Fire hydrant supply piping shall be a minimum of 6 inches in diameter. The lowest operating nut shall be a minimum of 18" above grade and the hydrant flange shall be a minimum of 2" above grade.
6. Fire hydrants shall be a minimum of 40' from all structures. A keyed gate valve shall be provided for each hydrant in an accessible location. Valves shall not be located in parking stalls.
7. All pipes shall be approved for use in fire service systems (Class 150

minimum). Class 200 pipe shall be used where the pressure may exceed 150 psi.

8. All ferrous pipe and fittings shall be protected with a loose 8-mil polyethylene tube. The ends of the tube and splices made for "T"s of other piping components shall be sealed with 2" tape, approved for underground use. Galvanizing does not meet the requirements of this section. All bolted joints shall be cleaned and thoroughly coated with asphalt or other corrosion retarding material after assembly and prior to poly-tube installation.
9. A 12" bed of clean fill sand shall be provided below and above the pipe (total 24").
10. All bolts used for underground connections shall be stainless steel.
11. A minimum of 30" of cover, from finish grade to the top of the pipe, shall be provided. When surface loads are expected, a minimum of 36" cover shall be provided.
12. Thrust blocks, or other approved method of thrust restraint, shall be provided wherever pipe changes direction.
13. The trench shall be excavated for thrust blocks and inspected prior to pour. All corrosion protection shall be in place.
14. A hydrostatic test (200 psi for two hours or 50 psi over maximum static pressure, whichever is greater) shall be witnessed by a Life Safety Services Inspector. The trench shall be back-filled between the joints to prevent movement of pipe.
15. The system shall be thoroughly flushed before connection is made to overhead piping. Flow shall be through a minimum of a 4" hose or pipe unless otherwise approved by the Life Safety Services Inspector. Inspector shall witness the flush.
16. Private hydrants, sprinkler control valves, post indicating valves and fire department connections shall be painted OSHA red.
17. All control valves shall be locked in the open position.
18. Contractor shall provide Life Safety Services a completed Contractor's Material and Test Certificate for Underground Piping and Aboveground Piping at time of final inspection in accordance with Chapter 10 and 13 of NFPA 13.

19. Provide sign on FDC in accordance with Newport Beach Life Safety Services Guideline F.03 - Identification of Fire Department Connections. Show sign on plan.
20. Post indicator valves shall be set so that the top of post will be 36" above final grade.
21. The Fire Department connection should be located not less than 18 inches and not more than 4' above the level of the adjacent grade or access level.
22. On site hydrants shall be provided with blue dot reflective markers.
23. Backfill shall be well tamped in layers and wetted under and around pipes to prevent settlement or lateral movement. Backfill shall consist of clean fill sand to a minimum 12" below and to a minimum of 12" above the pipe.
24. Only ductile iron pipe shall be used under buildings or as an approved listed assembly. Pipe under buildings shall terminate a maximum of 18" from the exterior wall and six inches above finished floor. A minimum of 2" clearance (interstitial space) shall be provided where the pipe passes through the floor wall.

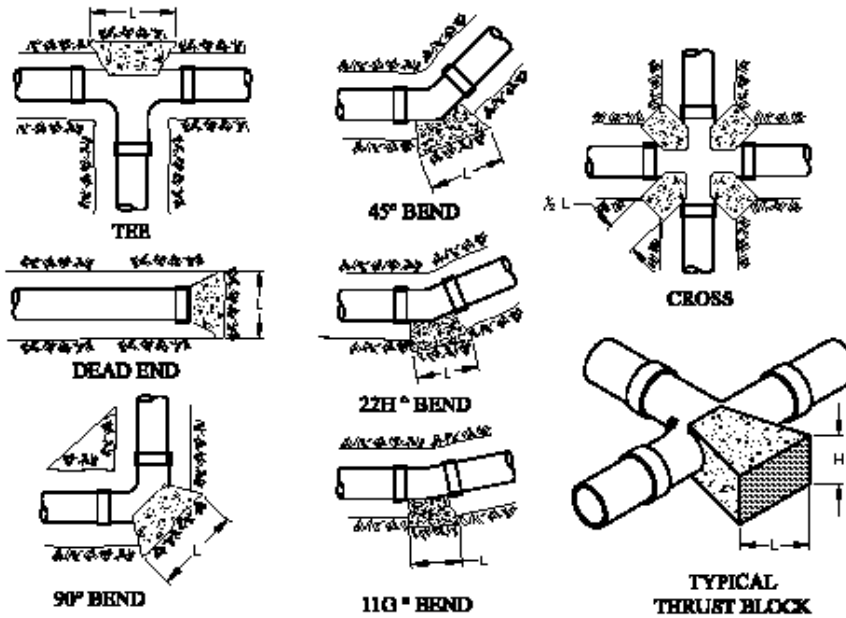

GENERAL NOTES:

- Force main pressure test shall be performed in accord with concrete curing requirements. Concrete shall be 3000-C-3000.
- Thrust blocks shall bear against undisturbed soil, backfill compacted to 100% relative compaction, or class 100 E 100 slurry.
- Bearing areas L x H are computed for test pressures of 225 PSI in water held in a cylindrical soil ($\mu=0$) with internal angle of friction of 37°, a unit weight of 110 PCF, and at least 36" of cover.
- Bearing areas L x H shall be approved by the engineer where: (A) bear against under soil than described above, (B) have less than 36" of cover, (C) will be tested at more than 225 PSI or (D) are not represented by a fitting or size shown herein.
- L is approximately equal to H for smaller thrust blocks. L is greater than H for larger thrust blocks. H shall not exceed trench height. See STD-100-L for standard trench dimensions.

THRUST BLOCK BEARING AREA L X H IN SQUARE FEET						
Fitting & Size	Dead End	Tee or Cross	90° Bend	45° Bend	22 1/2° Bend	110° Bend
4"	1.7	2.4	2.4	1.3	0.7	0.3
6"	3.7	5.3	5.3	2.9	1.5	0.7
8"	6.7	9.4	9.4	5.1	2.6	1.3
12"	15.0	21.2	21.2	11.3	5.9	2.9
16"	26.6	37.4	37.4	20.4	10.4	5.2
18"	33.7	47.6	47.6	25.8	13.1	6.6
24"	59.9	84.6	84.6	45.8	23.3	11.7
30"	93.6	132.2	132.2	71.5	36.5	18.3

CITY OF NEWPORT BEACH
PUBLIC WORKS DEPARTMENT

THRUST BLOCKS

APPROVED:

BSR NO. 16106

PUBLIC WORKS DIRECTOR

Drew M. Hill

Seale M.T.S.

Date: Jan. 2004

NEWPORT BEACH, CALIF.

DRAWING NO.

STD-510-L-A

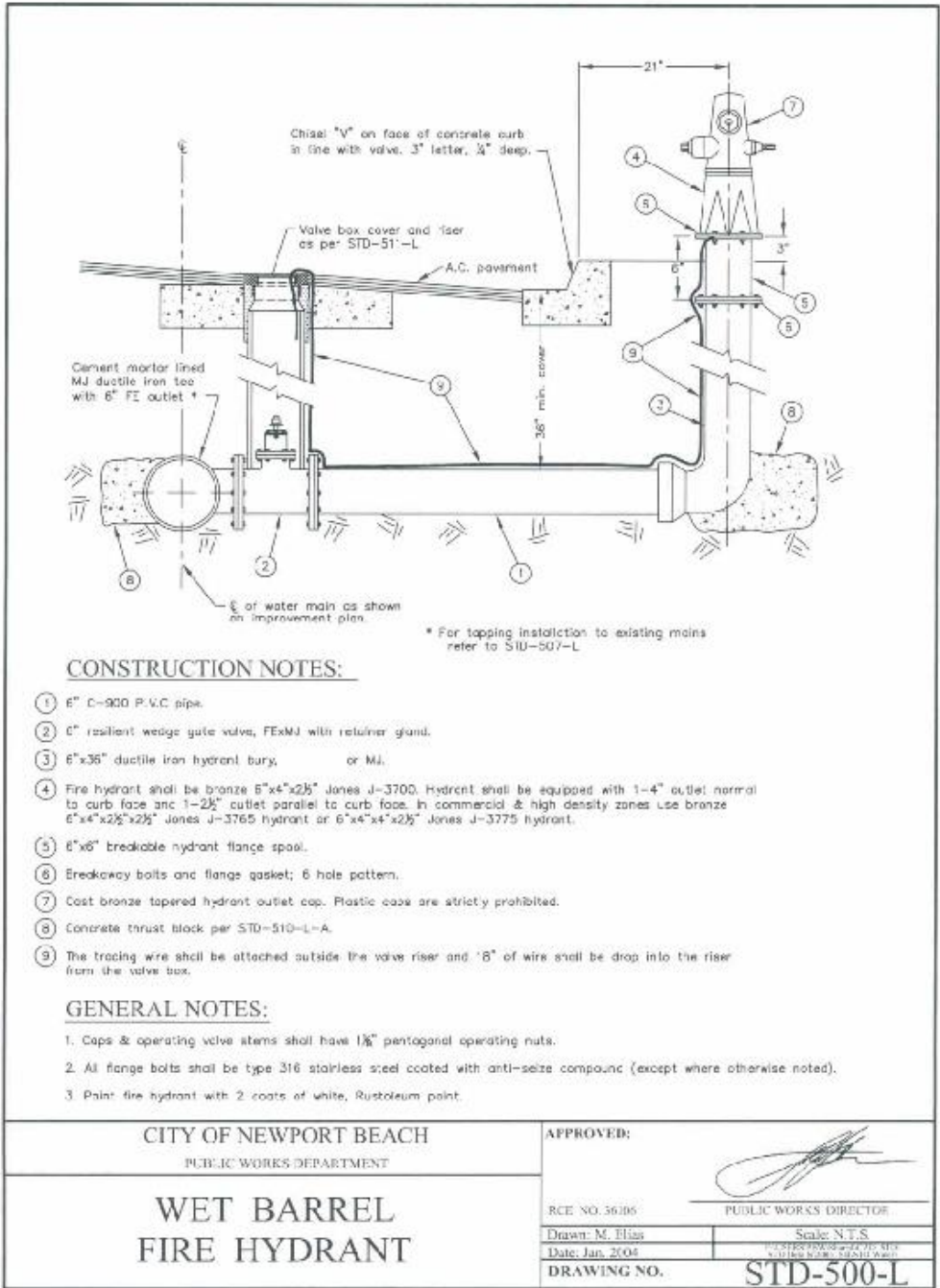

CONSTRUCTION NOTES:

- ① 6" C-900 P.V.C. pipe.
- ② 6" resilient wedge gate valve, FExMJ with retainer gland.
- ③ 6"x36" ductile iron hydrant bury, or MJ.
- ④ Fine hydrant shall be bronze 6"x4"x2 1/2" Jones J-3700. Hydrant shall be equipped with 1-4" outlet normal to curb face and 1-2 1/2" outlet parallel to curb face. In commercial & high density zones use bronze 6"x4"x2 1/2" Jones J-3765 hydrant or 6"x4"x4"x2 1/2" Jones J-3775 hydrant.
- ⑤ 6"x6" breakable hydrant flange spool.
- ⑥ Breakaway bolts and flange gasket; 6 hole pattern.
- ⑦ Cast bronze tapered hydrant outlet cap. Plastic caps are strictly prohibited.
- ⑧ Concrete thrust block per STD-510-L-A.
- ⑨ The tracing wire shall be attached outside the valve riser and "B" of wire shall be drop into the riser from the valve box.

GENERAL NOTES:

- 1. Caps & operating valve stems shall have 1 1/8" pentagonal operating nuts.
- 2. All flange bolts shall be type 316 stainless steel coated with anti-seize compound (except where otherwise noted).
- 3. Paint fire hydrant with 2 coats of white, Rustoleum paint.

<p>CITY OF NEWPORT BEACH PUBLIC WORKS DEPARTMENT</p>	<p>APPROVED:</p>  <p>PUBLIC WORKS DIRECTOR</p>
<p>WET BARREL FIRE HYDRANT</p>	<p>RCE NO. 36105</p> <p>Drawn: M. Elias Scale: N.T.S.</p> <p>Date: Jan. 2004</p> <p>DRAWING NO. STD-500-L</p>