

PLAN

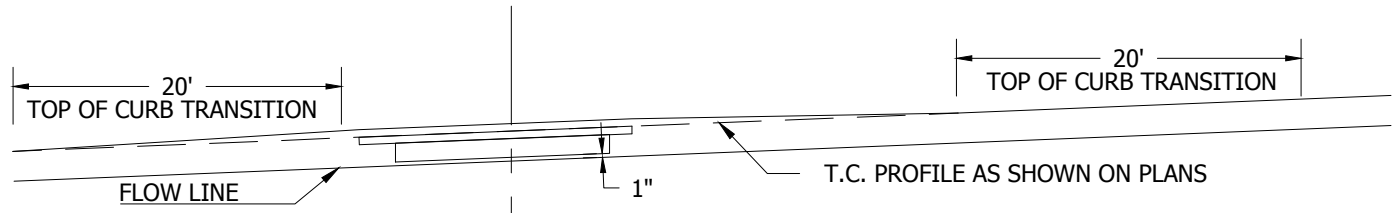

PROFILE

- NOTES**
1. USE PARKWAY CULVERT - TYPE "B" WHEN INLET VELOCITIES WILL BE LESS THAN 10 f.p.s..
 2. SEE STD 310 FOR DETAILS AND NOTES
 3. SPAN "S" AND HEIGHT OF OPENING AND CURB FACE AT CULVERT SHALL BE NOTED ON PLANS.
 4. SEE STD 310 FOR STEEL LIST.

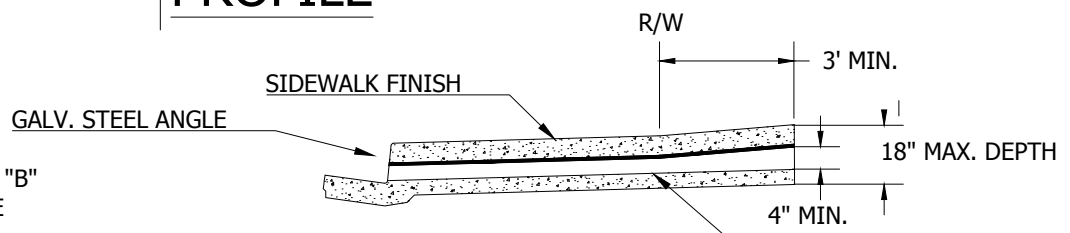

SECTION B-B
(CASE II INLET)

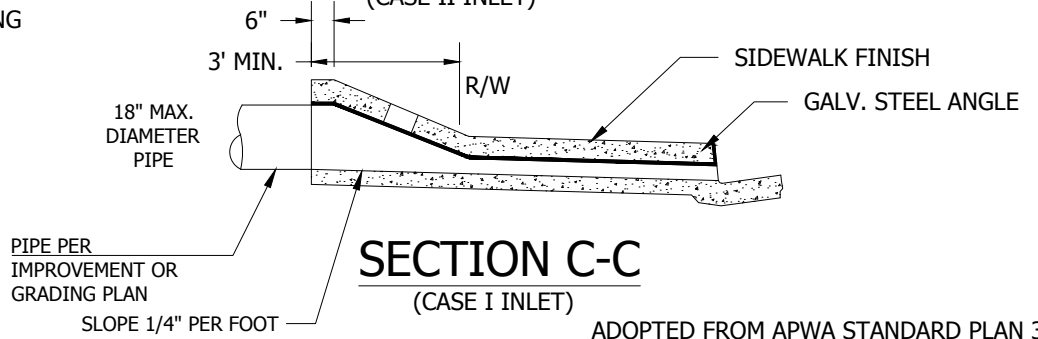

SECTION C-C
(CASE I INLET)

ADOPTED FROM APWA STANDARD PLAN 310-2
FORMER CITY STANDARD PLAN NUMBER (2004 EDITION): STD 318-L

APP. *James M. Hinkle* 51568 11/24/2020
CITY ENGINEER RCE DATE

NO.	DATE	DESCRIPTION OF REVISIONS

CITY OF NEWPORT BEACH DEPARTMENT OF PUBLIC WORKS

DRAWN: M. ELIAS
DATE: 11/3/2020

PARKWAY CULVERT TYPE "B"

STANDARD DRAWING NO.
308
SHEET 1 OF 1