

PLAN

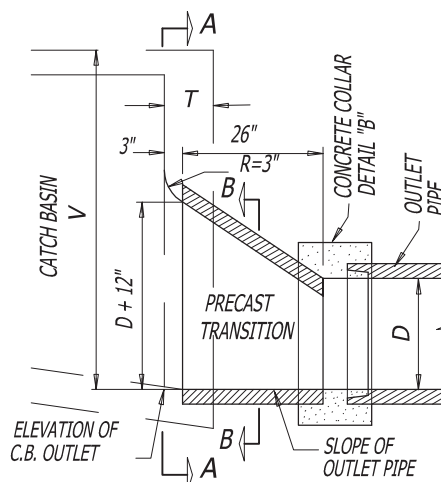

ELEVATION

CASE - 1

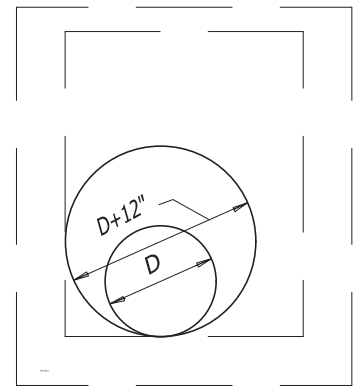

SECTION A-A

(E) & (F) - POINTS OF ROTATION

MODIFY TOP, BOTTOM, SIDES & END WALL OF CATCH BASIN. PLACE STEEL RADIALLY ON TOP OF SIDEWALK SLAB

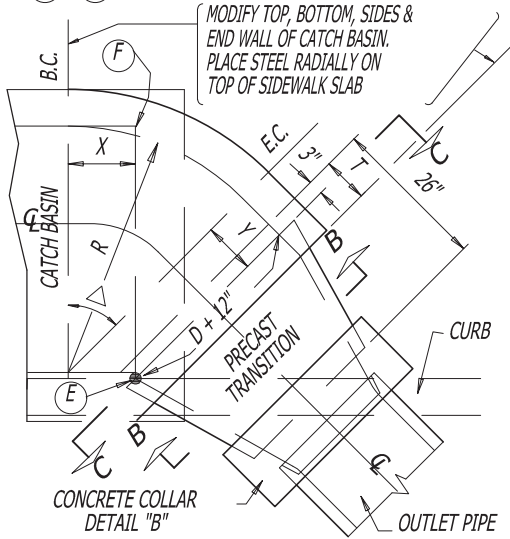

PLAN

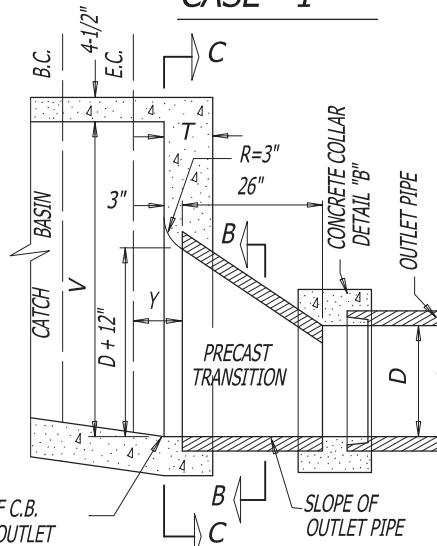

ELEVATION

CASE - 2

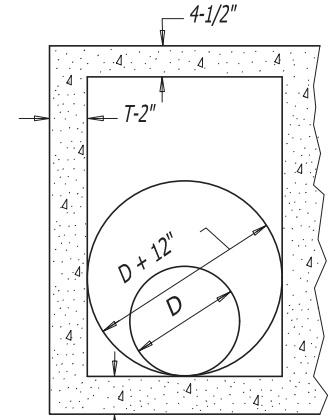

SECTION C-C

TABLE - A

D	△	R	X	Y
18"	30°	38"	16"	13-7/8"
18"	45°	38"	11-3/8"	8"
21"	30°	38"	10"	8-5/8"
21"	45°	38"	7-1/8"	5"
24"	30°	38"	4"	3-1/2"
24"	45°	38"	2-7/8"	2"
27" OR MORE	30°	D+12"	0"	0"
	45°	D+12"	0"	0"

TABLE - B

D	18"	21"	24"	27"	30"
G	7"	7"	7-1/2"	8"	8"

"A" BARS #4 @ 6"

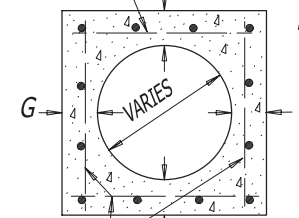

SECTION D-D

PRECAST TRANSITION SHALL BE REINFORCED FOR (1250-D) FOR D+12 R.C.P.

"L" SHALL NOT EXCEED 24"

MIN. 3-#4 "A" BARS. MAX. SPACING 6"

PRECAST TRANSITION MIN. 4-#4 TIES TOP, SIDES & BOTTOM MAX. SPACING 18"

MIN. 2-#4 "D" BARS MAX. SPACING=12"

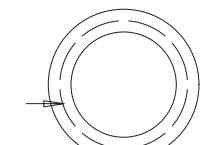

SECTION B-B

DETAIL B

SQUARE CONCRETE COLLAR

MIN. OF 4-#4 TIES ON SIDES, TOP & BOTTOM MAX. SPACING = 18"

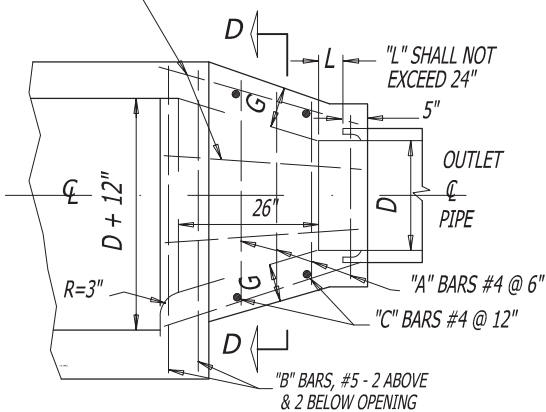

PLAN

STEEL REINFORCING

DETAIL A

MONOLITHIC TRANSITION

ADOPTED FROM CITY OF LOS ANGELES STD. PLAN B-3649

APP. *James M. Hinkle* 51568
CITY ENGINEER RCE

11/24/2020
DATE

NO.	DATE	DESCRIPTION OF REVISIONS

CITY OF NEWPORT BEACH DEPARTMENT OF PUBLIC WORKS

DRAWN: M. ELIAS

DATE: 11/3/2020

CURB INLET BASIN OUTLET TRANSITION STRUCTURE

STANDARD DRAWING NO.

303

SHEET 1 OF 2

REV. 9/93

FORMER CITY STANDARD PLAN NUMBER (2004 EDITION): STD 302-L-A

NOTES FOR CATCH BASIN OUTLET TRANSITION STRUCTURE

- 1 - TRANSITION MAY BE EITHER PRECAST OR MONOLITHIC AT INSPECTOR'S OPTION.
- 2 - PRECAST TRANSITION SHALL BE REINFORCED FOR 1250-D FOR D+12 INCH CONCRETE PIPE.
- 3 - CONCRETE COLLAR (DETAIL "B") SHALL BE USED ONLY TO JOIN THE PRECAST TRANSITION WITH THE OUTLET PIPE.
- 4 - CONCRETE SHALL BE OF THE SAME CLASS AS THE STRUCTURE WITH WHICH IT IS POURED.
- 5 - CURVATURE OF THE ROUNDED EDGE OF THE OUTLET AND SIDEWALLS SHALL BE FORMED BY CURVED FORMS AND SHALL NOT BE MADE BY PLASTERING.
- 6 - INTERIOR SURFACE OF STRUCTURE SHALL BE SMOOTH AND CLEAN, AND FREE FROM POCKETS OR PROTUBANCES.
- 7 - SURFACE OF ALL EXPOSED CONCRETE SHALL CONFORM IN SLOPE, GRADE, COLOR, FINISH AND SCORING TO EXISTING OR PROPOSED CURB AND WALK ADJACENT TO THE BASIN.
- 8 - DIMENSIONS "T", "V", AND STEEL REINFORCEMENT DETAILS ARE SHOWN EITHER ON STANDARD PLAN OR ON THE IMPROVEMENT PLAN FOR THE CATCH BASIN.
- 9 - OUTLET PIPE SHALL BE TRIMMED TO FINAL SHAPE AND LENGTH BEFORE CONCRETE IS POURED.
- 10 - REINFORCING STEEL SHALL BE 1½" CLEAR FROM FACE OF CONCRETE UNLESS OTHERWISE SHOWN.
- 11 - TRANSITION STRUCTURE (CASE 2) MAY BE CONSTRUCTED IN ANY DIRECTION WITHIN THE LIMITS OF TABLE "A" AS SPECIFIED ON THE IMPROVEMENT PLAN, BY ROTATING IT ABOUT EITHER POINTS "E" OR "F".

ADOPTED FROM CITY OF LOS ANGELES STD. PLAN B-3649

FORMER CITY STANDARD PLAN NUMBER (2004 EDITION): STD 302-L-B

APP.	 CITY ENGINEER	51568 RCE	11/24/2020 DATE		
				NO.	DATE
				DESCRIPTION OF REVISIONS	

CITY OF NEWPORT BEACH DEPARTMENT OF PUBLIC WORKS

DRAWN: M. ELIAS	<h1 style="margin: 0;">CURB INLET BASIN OUTLET TRANSITION STRUCTURE</h1>	STANDARD DRAWING NO. <h1 style="margin: 0;">303</h1>
DATE: 11/3/2020		SHEET 2 OF 2