

ELEVATION

NOTES:

1. DRAINS WITH SLOPE GREATER THAN 10% MAY REQUIRE AN ENERGY REDUCER.
2. ALL DRAINS MUST BE INSTALLED 90° TO THE CURB FACE UNLESS APPROVED BY THE CONSTRUCTION ENGINEER.
3. IF CURB AND GUTTER OR SIDEWALK IS REMOVED, JOIN TO THE NEAREST JOINT.

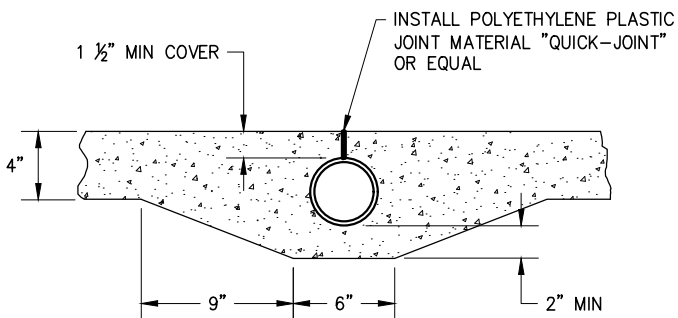

**SECTION A-A
RESIDENTIAL**

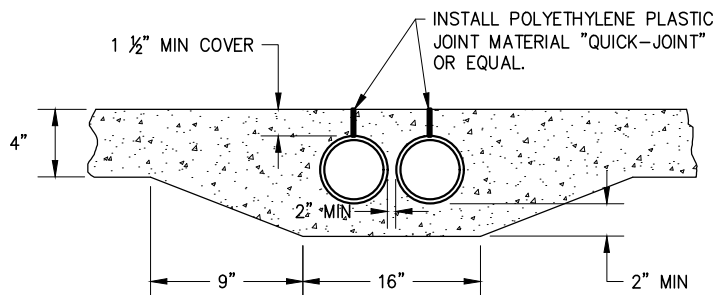

**SECTION A-A
COMMERCIAL**

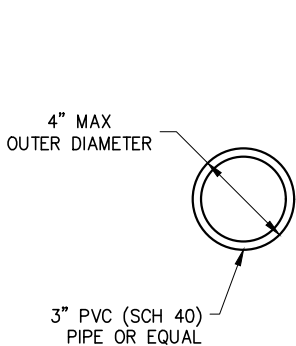

DETAIL A

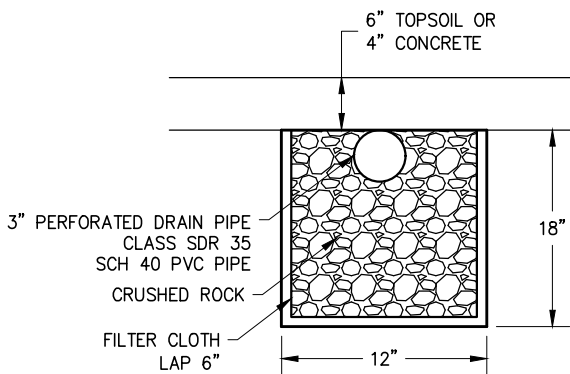

SECTION B-B

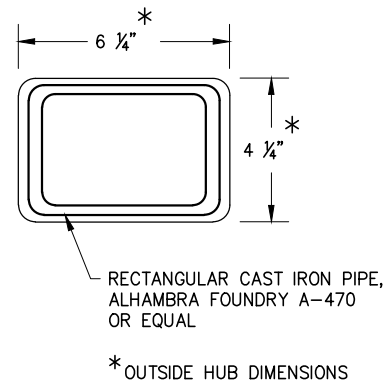

ALTERNATE TO DETAIL A

FORMER CITY STANDARD PLAN NUMBER (2004 EDITION): STD 184-L

APP. *James M. Hinkle* 51568 11/24/2020
 CITY ENGINEER RCE DATE

NO.	DATE	DESCRIPTION OF REVISIONS

CITY OF NEWPORT BEACH DEPARTMENT OF PUBLIC WORKS

DRAWN: P. KHARAZMI
 DATE: 11/3/2020

PRIVATE DRAINS THROUGH CURB

STANDARD DRAWING NO.

184

SHEET 1 OF 1