

**NOTES:**

1. R=25' FOR COMMUTER STREETS AND 35' FOR ARTERIAL STREETS UNLESS OTHERWISE SPECIFIED.
2. CONCRETE SHALL BE 560-C-3250.
3. LANDSCAPE PARKWAY WITH STREET TREES REQUIRED WHEN DISTANCE FROM CURB FACE TO PROPERTY LINE EXCEEDS 6' IN RESIDENTIAL AREAS. CONCRETE SIDEWALK IN COMMERCIAL AREAS WITH STREET TREES.

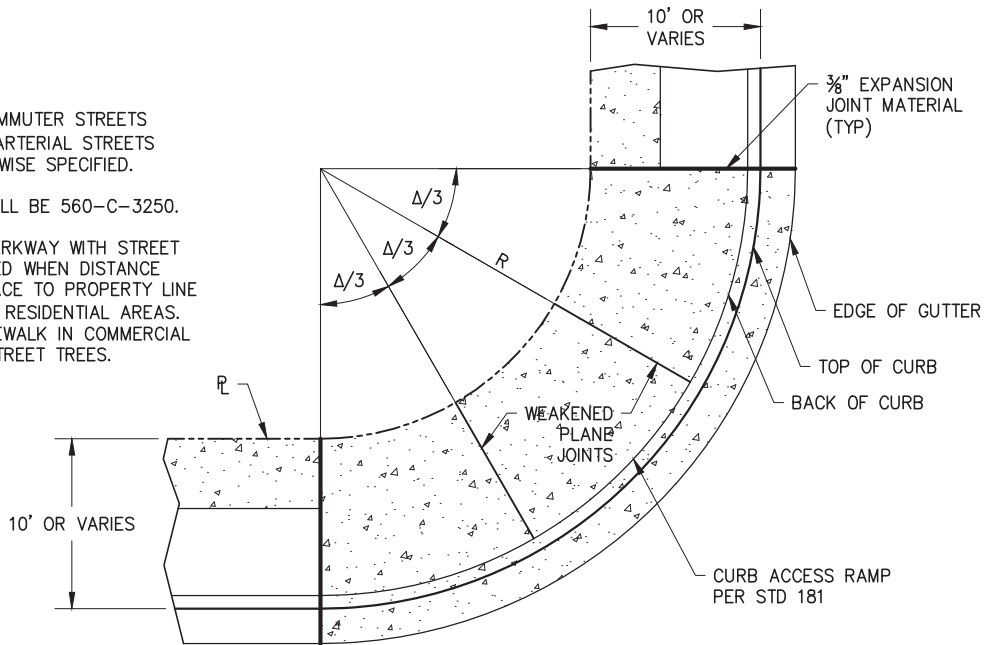

**CURB RETURN AREA**

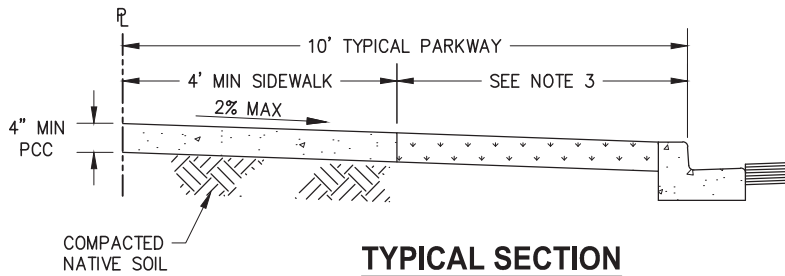

**TYPICAL SECTION**

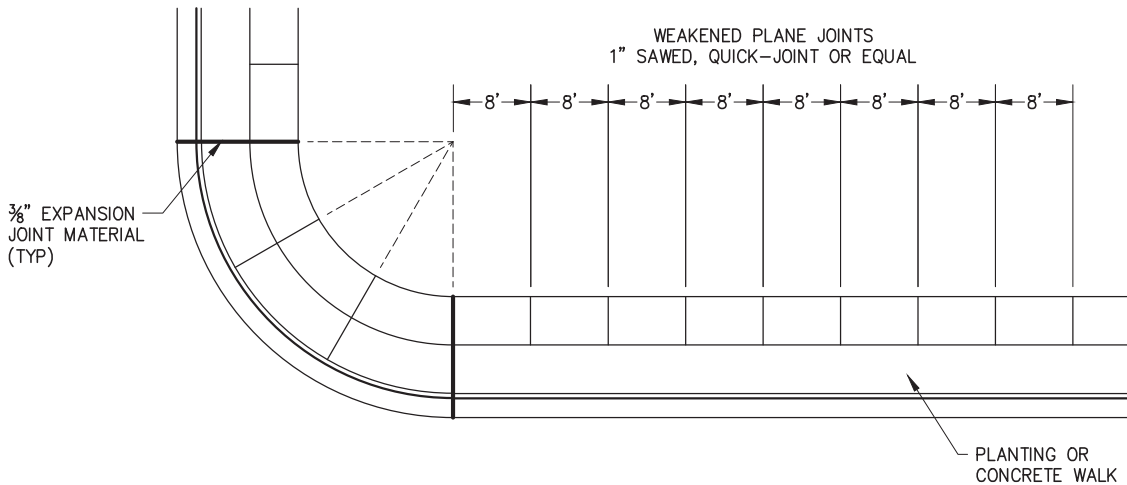

**WEAKENED PLANE JOINTS & EXPANSION JOINTS**

FORMER CITY STANDARD PLAN NUMBER (2004 EDITION): STD 180-L

APP. *James M. Hinkle* 51568 11/24/2020  
 CITY ENGINEER RCE DATE

NO.	DATE	DESCRIPTION OF REVISIONS

**CITY OF NEWPORT BEACH DEPARTMENT OF PUBLIC WORKS**

DRAWN: P. KHARAZMI  
 DATE: 11/3/2020

**SIDEWALK DETAIL**

STANDARD DRAWING NO.

**180**

SHEET 1 OF 1