

COVER FOR 24" CLEAR OPENING FRAME

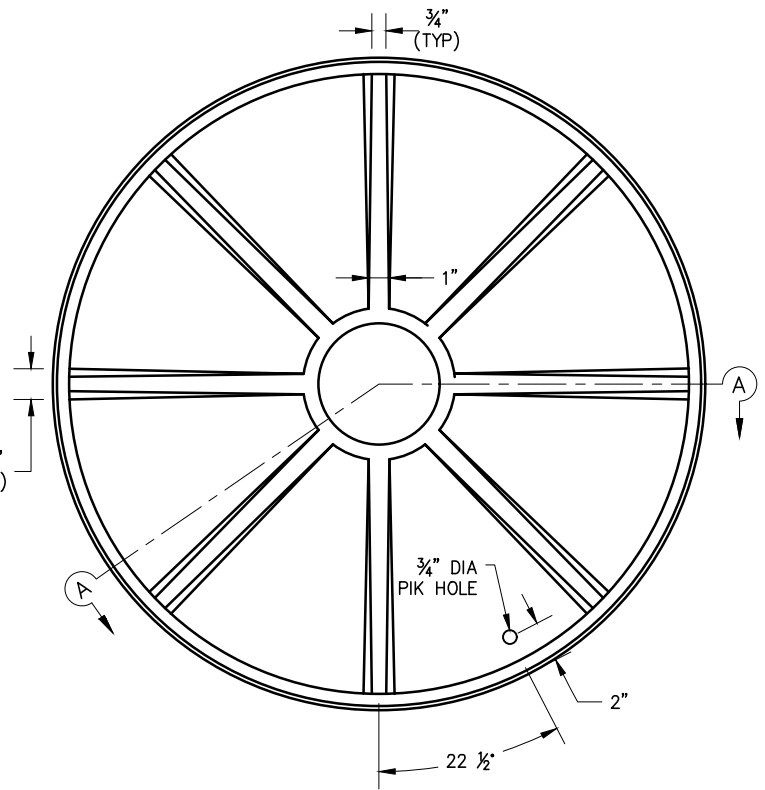

BOTTOM PLAN OF COVER

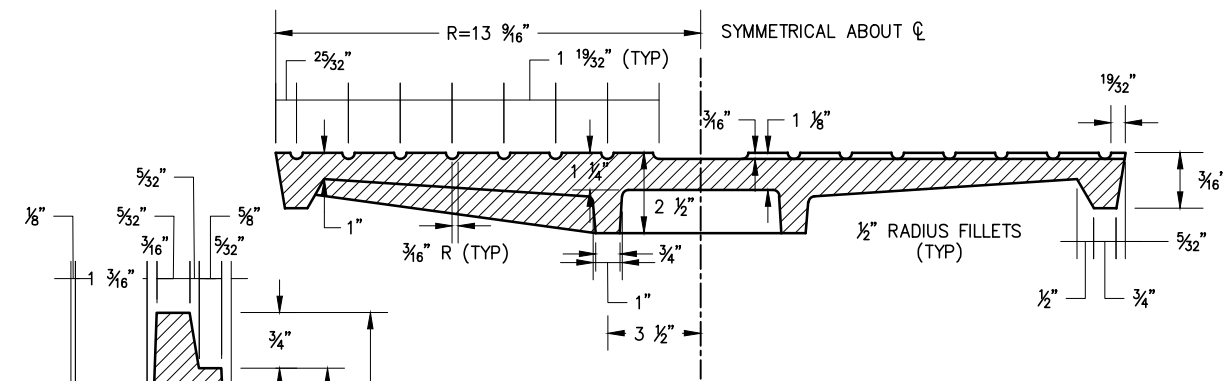

SECTION A-A

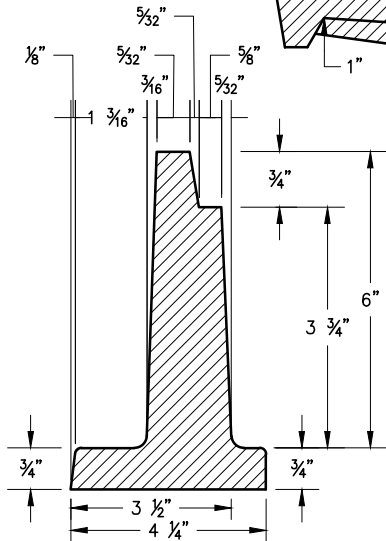

DETAIL OF FRAME

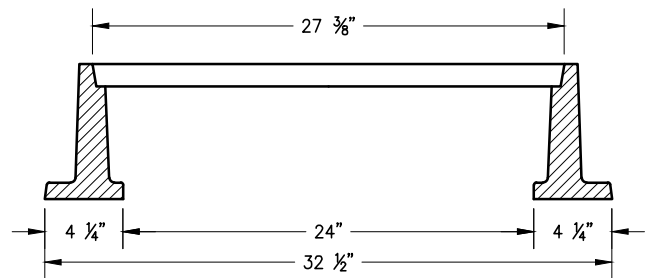

SECTION THRU FRAME

NOTES:

1. MANHOLE FRAME AND COVER SHALL BE MADE OF GRAY CAST IRON CONFORMING TO ASTM A-48, CLASS 30, AND PAINTED WITH ASPHALTUM PAINT EXCEPT FOR MACHINED SURFACES. (ALHAMBRA FOUNDRY A-1495).
2. STORM DRAIN (SANITARY SEWER) COVERS SHALL BE CAST WITH THE LETTER "D" ("S") IN THE CENTER OF THE COVER AND "NEWPORT BEACH" SHALL BE CAST IN THE COVER.

APP. <i>James M. Hinkle</i>	51568	11/24/2020			
CITY ENGINEER	RCE	DATE			
			NO.	DATE	DESCRIPTION OF REVISIONS

CITY OF NEWPORT BEACH DEPARTMENT OF PUBLIC WORKS

DRAWN: P. KHARAZMI	STANDARD MANHOLE FRAME AND COVER (24-INCH)	STANDARD DRAWING NO.
DATE: 11/3/2020		318
		SHEET 1 OF 3

FORMER CITY STANDARD PLAN NUMBER (2004 EDITION): STD 112-L

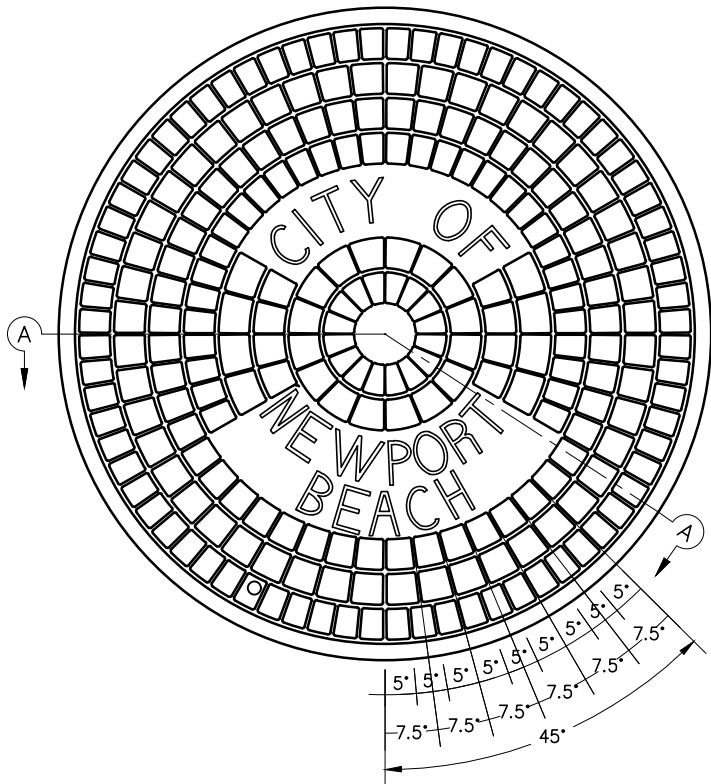

COVER FOR 27" CLEAR OPENING FRAME

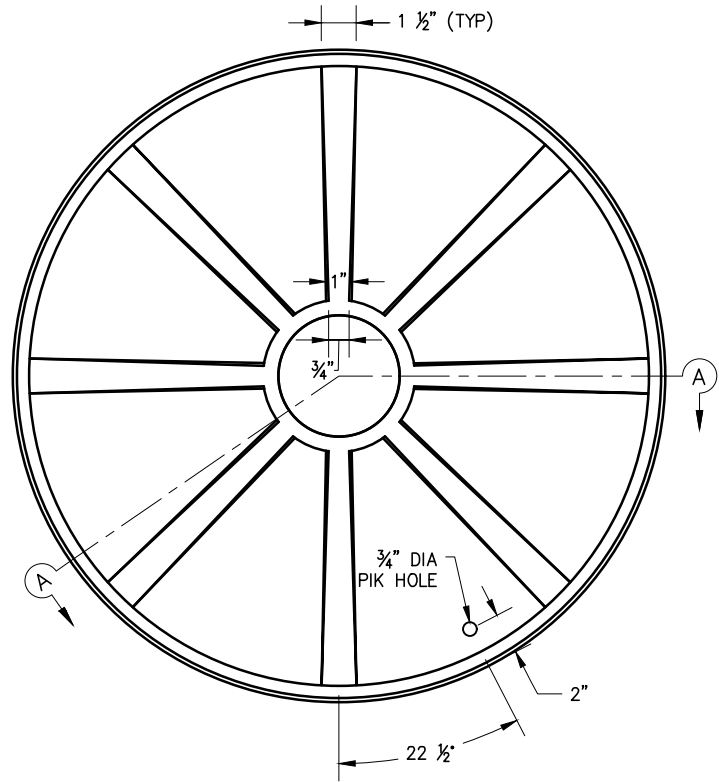

BOTTOM PLAN OF COVER

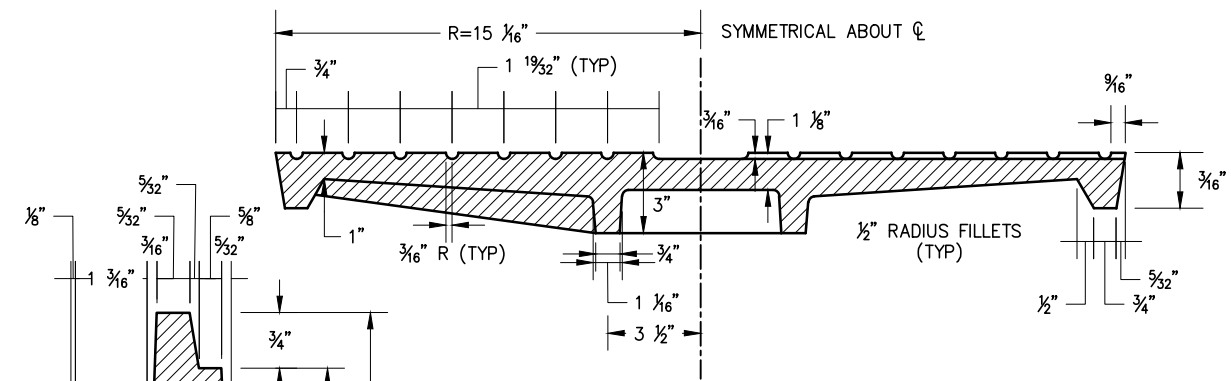

SECTION A-A

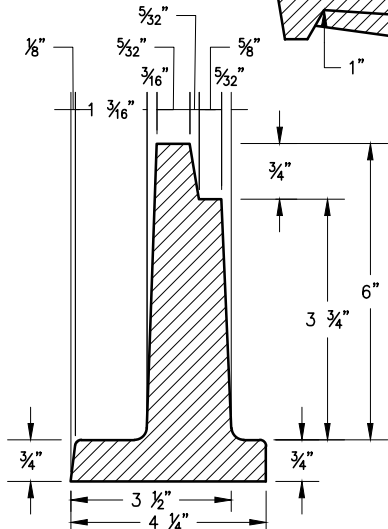

DETAIL OF FRAME

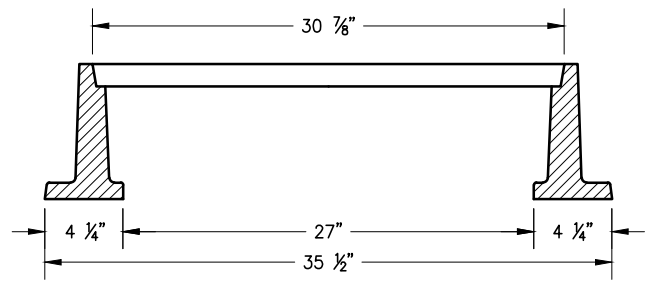

SECTION THRU FRAME

NOTES:

1. MANHOLE FRAME AND COVER SHALL BE MADE OF GRAY CAST IRON CONFORMING TO ASTM A-48, CLASS 30, AND PAINTED WITH ASPHALTUM PAINT EXCEPT FOR MACHINED SURFACES. (ALHAMBRA FOUNDRY A-1495).
2. STORM DRAIN (SANITARY SEWER) COVERS SHALL BE CAST WITH THE LETTER "D" ("S") IN THE CENTER OF THE COVER AND "NEWPORT BEACH" SHALL BE CAST IN THE COVER.

APP. <i>James M. Hinkle</i>	51568	11/24/2020			
CITY ENGINEER	RCE	DATE			
			NO.	DATE	DESCRIPTION OF REVISIONS

CITY OF NEWPORT BEACH DEPARTMENT OF PUBLIC WORKS

DRAWN: P. KHARAZMI	STANDARD MANHOLE FRAME AND COVER (27-INCH)	STANDARD DRAWING NO.
DATE: 11/3/2020		318
		SHEET 2 OF 3

FORMER CITY STANDARD PLAN NUMBER (2004 EDITION): STD 113-L

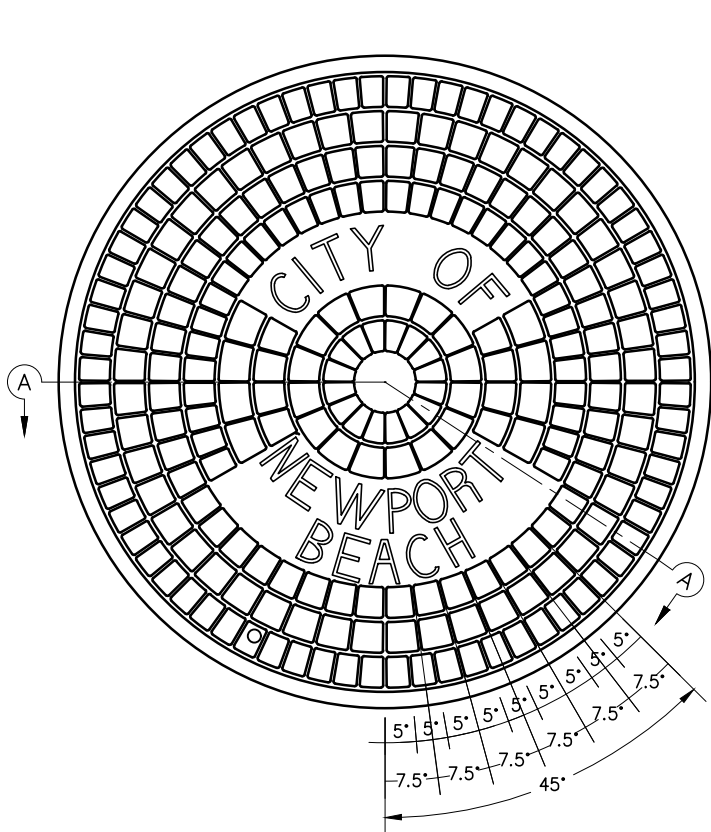

COVER FOR 30" CLEAR OPENING FRAME

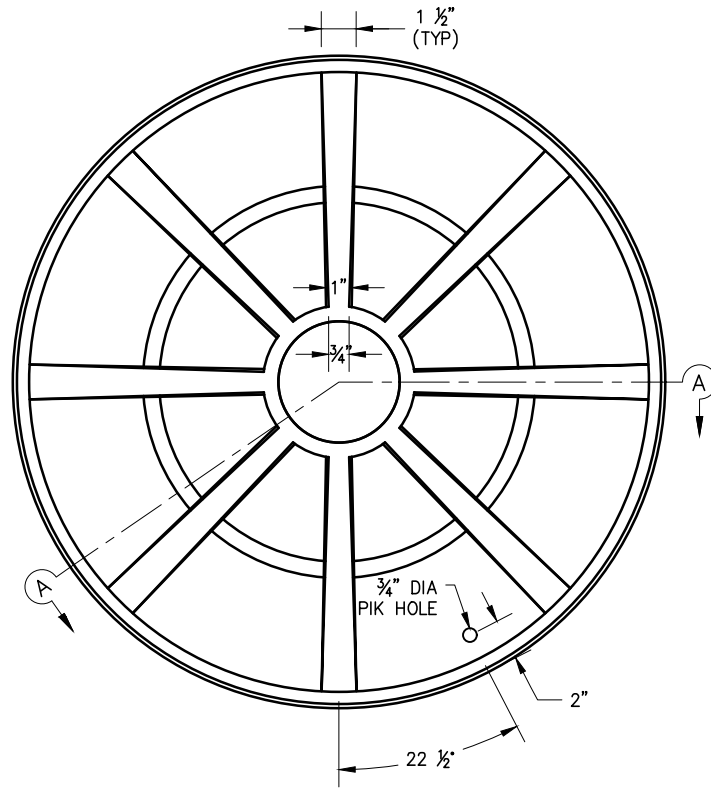

BOTTOM PLAN OF COVER

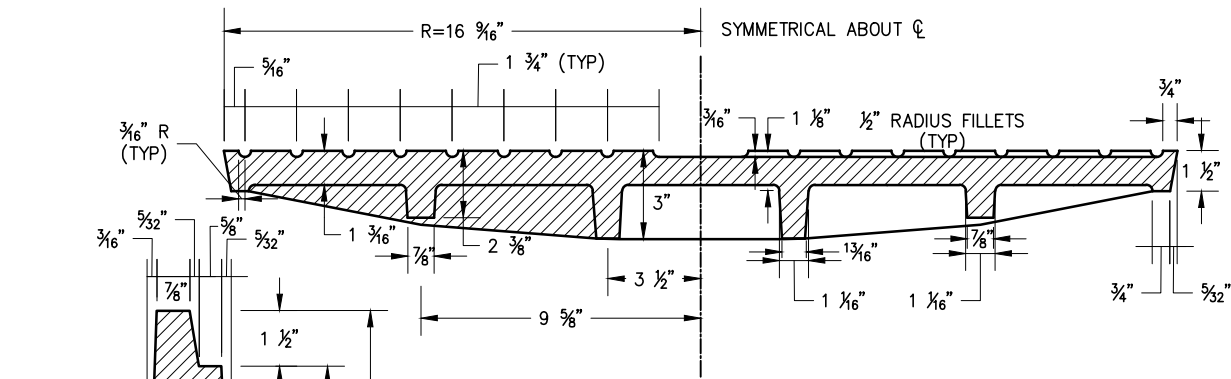

SECTION A-A

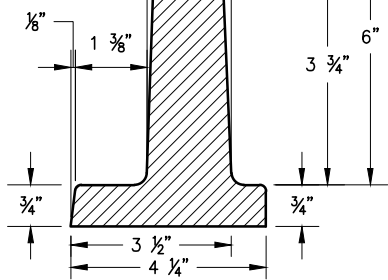

DETAIL OF FRAME

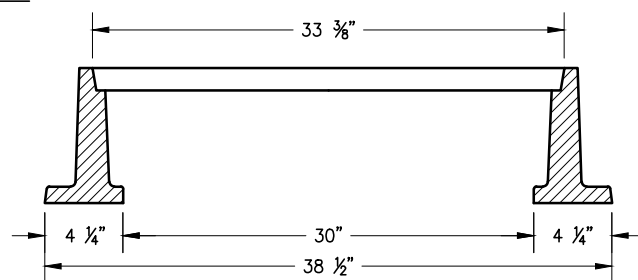

SECTION THRU FRAME

NOTES:

1. MANHOLE FRAME AND COVER SHALL BE MADE OF GRAY CAST IRON CONFORMING TO ASTM A-48, CLASS 30, AND PAINTED WITH ASPHALTUM PAINT EXCEPT FOR MACHINED SURFACES. (ALHAMBRA FOUNDRY A-1495).
2. STORM DRAIN (SANITARY SEWER) COVERS SHALL BE CAST WITH THE LETTER "D" ("S") IN THE CENTER OF THE COVER AND "NEWPORT BEACH" SHALL BE CAST IN THE COVER.

APP. *James M. Hinkle* 51568 11/24/2020
 CITY ENGINEER RCE DATE

NO.	DATE	DESCRIPTION OF REVISIONS

CITY OF NEWPORT BEACH DEPARTMENT OF PUBLIC WORKS

DRAWN: P. KHARAZMI
 DATE: 11/3/2020

**STANDARD MANHOLE FRAME AND COVER
 (30-INCH)**

STANDARD DRAWING NO.

318

SHEET 3 OF 3

FORMER CITY STANDARD PLAN NUMBER (2004 EDITION): STD 114-L