

GENERAL INFORMATION FOR SERVICE CONVERSION FROM OVERHEAD TO UNDERGROUND

1. **PRE-INSPECTION:** The City's Building Inspector, Jason Rudenick, at (949) 644-3262 has already performed a pre-inspection. The pre-inspection checklist will indicate whether further underground utility processes need to be taken, and whether a meter panel upgrade is recommended or required.

If your property has existing electric, telephone, and cable underground services, no further action will be necessary after the pre-inspection. If one or more of the existing services need to be undergrounded, please note the following steps.

2. **RETAIN A QUALIFIED CONTRACTOR:** The contractor you retain must possess one of the following contractor's license to perform the private underground conversion work:

- C-10: Electrical Contractor (Specialty)
- A: Engineering Contractor
- B: General Building Contractor
- Owner/Builder

It is strongly recommended that you obtain at least 3 bids from contractors and ask for references in order to get a reputable contractor that will provide the highest quality of work at the lowest possible price. Please refer to the California Contractor's State License Board for further information on hiring a contractor.

3. **OBTAIN ELECTRICAL PERMIT:** Once a contractor has been selected, your contractor should go to the City's Building Department to obtain an Electrical Permit and SCE design. Please have your contractor bring the pre-inspection checklist with him/her. If you have any questions regarding the Electrical Permit, please contact the City's Building Department at (949) 644-3275.

4. **DETERMINE METHOD OF CONNECTION:** The contractor will need to obtain a SCE plan at the City's Public Works Counter prior to any excavation (see step 3). The Contractor/Customer must not deviate from the SCE plan without first obtaining prior approval from SCE. The SCE underground inspector Enrique Cortez (714) 895-0448 can be contacted for pre-construction questions with regards to trench and duct requirements. Please note that any existing, non-conforming services may need to be upgraded and/or relocated.

Attached are exhibits for appropriate requirements to underground your electric, telephone, and/or cable services. All installations shall comply with the rules and regulations of the City of Newport Beach along with all applicable governing laws and ordinances, Southern California Edison, AT&T, and Time Warner Cable.

Note: Public documents such as the Southern California Edison Electrical Service Requirements manual which can be found on the web @ <https://www.sce.com/regulatory/distribution-manuals/electrical-service-requirements> should be utilized prior to contacting your local SCE planning or Inspection offices.

SPECIAL SCE PROVISIONS:

Should your electrical panel be an older style without a conduit knockout, best and safest practice would be to replace your panel. Should this not be feasible, SCE has other approved options that are listed below, and detailed in SCE's Electrical Service Requirements, page 3-32 (enclosed):

- Keep existing service and connect underground conduit from point of connection and sweep inside of exterior wall into service side of panel (Example A – ESR-3); or
- Install new meter and distribution fuse meter for underground service (Example B – ESR-3); or
- Keep existing service and connect surface mounted pull box and conduits/weatherproof enclosed gutter (connect on service mast of room, Example D – ESR-3).

5. CONDUIT EXTENSION: The contractor shall extend an approved plastic conduit for each of the overhead services to be undergrounded.

UNDERGROUND CONDUIT SIZES:

Electrical: One three-inch (3") conduit (residential applications only)
Telephone: One two-inch (2") conduit
Cable: One one-inch (1") conduit

Please refer to the attached exhibits from each utility company for specific information regarding the installation.

GENERAL SCE PROVISIONS:

- Provide a minimum three-foot (3') clearance in front and side-to-side of meter location.
- Meter height must meet 4'-0" to 6'-3" from final grade to centerline of meter.
- Provide 36-inch sweeps.
- Conduits to be placed a minimum of 33 inches below finished grade measured from the top of conduit.
- Provide 12-inch separation from other utilities, 6 inches for crossings.
- Install a yellow 3/8" pole pull rope in the conduit for mandrel.

6. CALL FOR INSPECTION: An inspection approval shall be obtained from the City's Building Department and SCE Inspector for the conduit installation PRIOR to backfilling the trench. Please provide a minimum 48 hour notice for inspections and or pre-con meeting requests.

*Note final SCE inspection and signing of the jobsite card by SCE inspector will not take place until all conduit is installed according to SCE plan, trench is backfilled, panel upgraded/replaced (if necessary), rope installed and mandrel witnessed.

For City Inspection requests please utilize our automated system at 949-644-3255 or ONLINE at <https://newportbeachca.gov/government/departments/community-development/building-division/building-permit-inspection-request-status>
Jason Rudenick, City Building Inspector, at (949) 644-3262
Enrique Cortez, SCE Inspector (714) 895-0448

7. METER PANEL UPGRADE AND BACKFILLING: All meter panel installations shall comply with the rules and regulations of the City of Newport Beach along with all applicable governing laws and ordinances and the Electrical Services Requirements of Southern California Edison.

<https://www.sce.com/regulatory/distribution-manuals/electrical-service-requirements>

All work in the public right-of-way will require an approved encroachment permit from the Public Works Department.

All backfilling shall comply with City Building Department requirements, and Public Works Department requirements, if applicable.

CALL FOR "ROUGH SERVICE RELEASE" INSPECTION: Once the work described in Step 7 is complete, the contractor shall call the City of Newport Beach, for a "rough service release" inspection. A "rough service release" must be approved prior to SCE "cut-over".

For City Inspection requests please utilize our automated system at 949-644-3255 or ONLINE at <https://newportbeachca.gov/government/departments/community-development/building-division/building-permit-inspection-request-status>

Once Step 7 has been completed, the owner/contractor shall await for further notice from SCE to schedule a "cut-over" as described in Step 8.

8. SCHEDULE CUT-OVER: Once 90 percent of the District receives the appropriate City and SCE "releases," SCE will contact contractors to schedule a "cut-over" to the electrical panel. The contractor must be present at the scheduled "cut-over" time. All SCE overhead conductor will be removed by SCE and the overhead riser mast

will be cut and capped by homeowners contractor once cutover complete. This step is to complete the actual work to convert overhead services to underground services.

A “cutover” appointment is not necessary for telephone and cable services. Once the appropriate conduits are extended, AT&T and TWC will have staff pull cable to your property’s point of connection. It should be noted that your contractor may be contacted by AT&T and/or TWC if conduits and associated work is not compliant. .

9: SCHEDULE A FINAL INSPECTION: A final City inspection shall be made to ensure that all work is complete, including pavement/concrete restoration. The Electrical Permit will not be “finaled” until this step has been taken.

If any questions arise concerning these requirements, please contact the City’s Building Department at (949) 644-3275 or your SCE Local Service Planning Office at (714) 895-0110.

General Notes/Specifications per National Electrical Code and Utility Standards:

Dig Alert – The State of California Government Code 4216 mandates that anyone doing excavation work shall call at least two working days prior to commencement of any excavation. Please call (800) 227-2600 or 811.

Newport Beach Municipal Code

1. Exposed PVC conduit shall be a minimum of schedule 80. Nonmetallic conduit installed on the exterior in runs greater than twenty-five feet (25’) require expansion fittings per NEC 300-5 & 347-9.
2. Grounding electrode and water bonding to be checked and upgrades if necessary sized per NEC T-250-94 & T-250-95.
3. All conduits, fittings and boxes sized per wire capacity of NEC-370-16 (Appendix C).
4. Maintain proper clearance for working spaces at new services and pull boxes. Minimum width of 36” x 36” depth x 78” in height per NEC 110-16.
5. Service equipment exposed to the weather shall be rain-tight NEC 370-15.
6. For each and every meter, the contractor shall furnish and install a switch, or other approved disconnecting means with over-current protection. (NEC allows up to a maximum of six (6) switches or disconnects to constitute the main over-current device) NEC 230-42; 230-71; 230-79.
7. If existing sub-panel(s) remain down line of new service disconnects, protection of existing may need to be supplied with a new additional panel giving protection the same as that of the old system. NEC 230-42; 310-15.
8. All meter fittings shall be mounted on a substantial support in a true vertical position. NEC 110-12.
9. All equipment, devices, and components shall be listed (recognized testing laboratory). NEC 100.

In the event where there are discrepancies amongst codes, the more stringent shall prevail.



AT&T

Specifications

Trenching

Conduit

Boxes

A Guide for California Residential Property Owners in a Municipal Underground District

This guide consists of AT&T California specifications and diagrams for trenching and underground support structure and other make ready work performed by property owners and their agents as required by AT&T for conversion of its aerial communication facilities on residential private property. Any deviation from the specifications provided in this document must be approved by the local AT&T Engineer.

TABLE OF CONTENTS

General Information on Underground Districts.....	3
General Construction Requirements	3
Trenching.....	4
Conduit.....	5
Pull Boxes	6
Pull Box Diagram.....	7
Bonding and Grounding	8

General Information on Underground Districts

Your local municipality has passed an ordinance in your neighborhood for the conversion of aerial communication and power facilities to underground facilities. The area to be converted from aerial to underground facilities is referred to as the "District".

AT&T's California Public Utility Commission Tariff Schedule A2 defines responsibilities for both the property owner and AT&T to convert the communication facilities on private property as described below.

The property owner is responsible for the trenching and underground supporting structure (conduit and pull boxes) between the public way and the building on your private property.

AT&T is responsible for converting the existing aerial service wire or cable to underground using the supporting structure provided by the property owner.

The trench work on the private property must be completed prior to the start of construction scheduled for your neighborhood street.

General Construction Requirements

4. Construct trench and place substructures according to AT&T plans and specifications.
5. Request and get authorization for any design change from the AT&T engineer or AT&T inspector prior to implementing the change.
6. Call [insert phone no.] for questions or information regarding the requirements in this Guide.
7. All trenching and conduit work must be completed on your private property before the scheduled date for conversion of facilities on your neighborhood street.

Trenching

1. The trench route from the telephone box on your house to the boundary of the street at your property line will be determined by AT&T.
2. Minimum radial clearance from all other trench occupants, except CATV, must be no less than 12 inches. A minimum 24" of coverage (dirt backfill) over the conduit is required within 5' of your property line (trench depth should be 27"). A minimum of 18" of coverage is acceptable for the remainder of the trench.
3. There may be no more than two 90 degree bends or a combination of bends that exceed 180 degrees total. If this requirement can not be met, then a minimum size 11" x 17" pull box must be installed in the conduit run in lieu of the bend. Consult with the AT&T engineer if necessary.

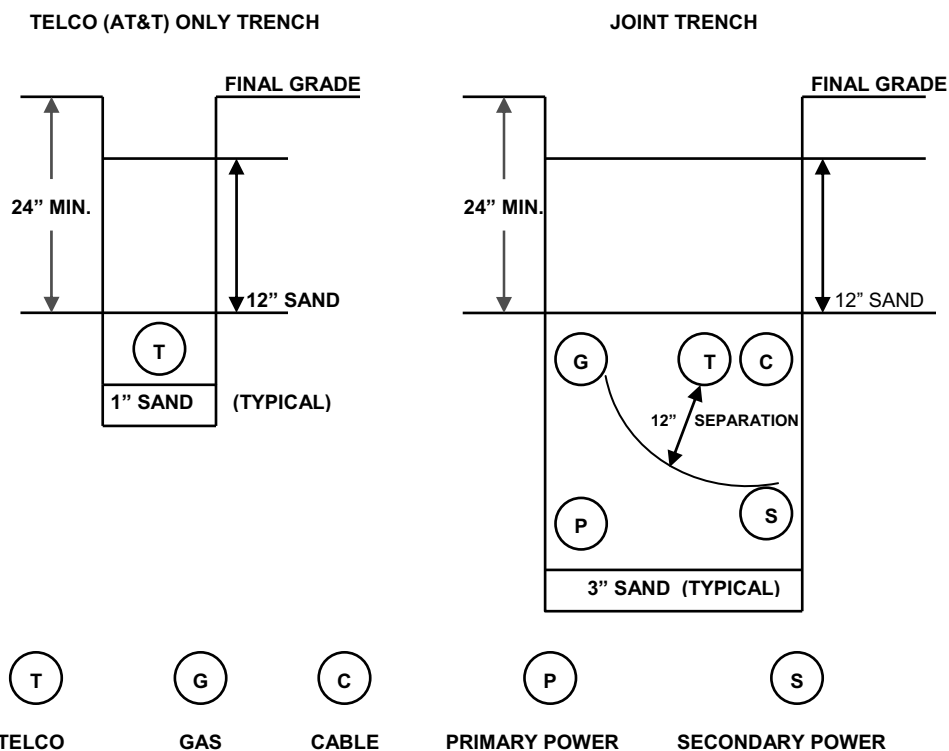

Conduit

Conduit placed for AT&T must be for its exclusive use. AT&T will not occupy the same conduit with other utilities or foreign cable/communication systems. AT&T may refuse to occupy conduit that deviates from our plans and specifications.

The property owner is responsible for repairing or resolving any problems with the conduit they have installed that prevents AT&T from pulling its wire through the conduit using normal installation methods. Conduit must be rodded, cleared, and roped prior to AT&T pulling in wire.

Material Requirements

1. Two inch (2") conduit must be type PTS 66/DB 120 rigid plastic or Schedule 40.
 - Minimum sweep for 2" conduit is a two ft 90 degree radius
 - Maximum of two (2) 90 degree bends
 - Install one quarter inch (1/4") plastic rope pull line, No. 12 pull wire, or weather proof pull tape
2. Rigid steel, condulets, plumber's fittings, flexible tubing, or water and gas pipes are not acceptable materials.

Installation Requirements

1. Minimum trench coverage for conduit is detailed under Trenching.
2. Conduit must be terminated into the ends or sides of the box. Conduit may not enter the bottom of the box.
3. Conduits at the house must be plugged by the property owner to provide a seal against water intrusion.
4. Use a temporary universal plug to keep conduit free of debris. Cap all stubbed conduit. Stake conduit at property line for AT&T tie-in.

Pull Boxes

Material Specifications

All pull boxes that will be owned and maintained by the property owner must be approved for use by AT&T. You may purchase from any manufacturer that meets AT&T's specifications for boxes. Boxes placed on private property and owned by the property owner must have a generic telephone emblem on the lid. The use of AT&T's name or logo is not permitted on a property owner's box. The pull box must be for AT&T's exclusive use. AT&T will not install its facilities in any box that is also being used by other utilities.

Installation Specifications for Boxes

1. Boxes must be installed at the final grade of the property.
2. A pull box for drainage and to prevent water from entering your house is required on your property at the property line when the conduit to the telephone box on your house is below sidewalk elevation or when your house is more than 2% down grade from the street elevation.
3. A minimum of six inches (6") of compacted sand, graded level is required under all pull boxes. Equip each box with sump hole and crushed rock for drainage.
4. Conduit must terminate at the end wall or side wall of a pull box. Entry through the bottom of a box is not acceptable.
5. All conduits entering knockouts in a plastic or polymer box must be cut within one inch (1") flush with the inside of the wall and sealed. Bush ends on conduit to remove sharp edges. All joints must be mortared and all unused ports and openings sealed. Use cement mortar, water plug cement or other approved prepared mortars.

CONDUIT TERMINATIONS IN PULL BOXES

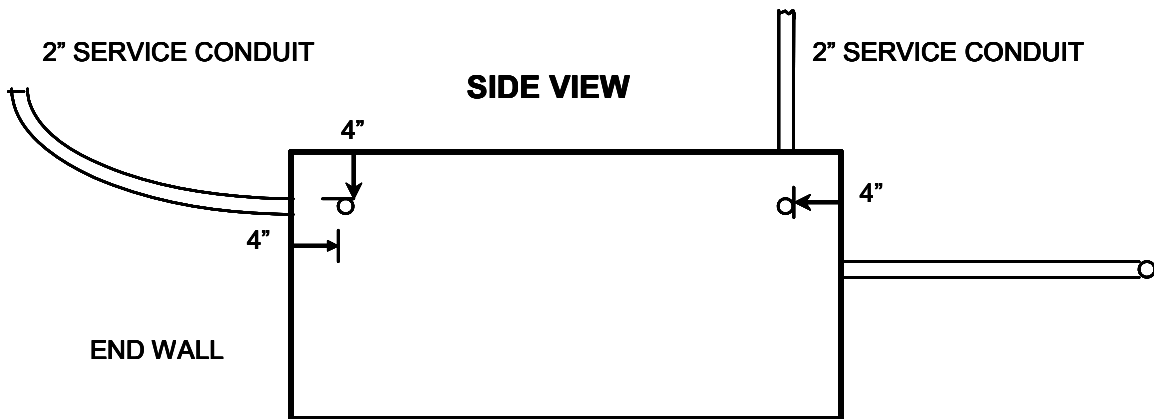
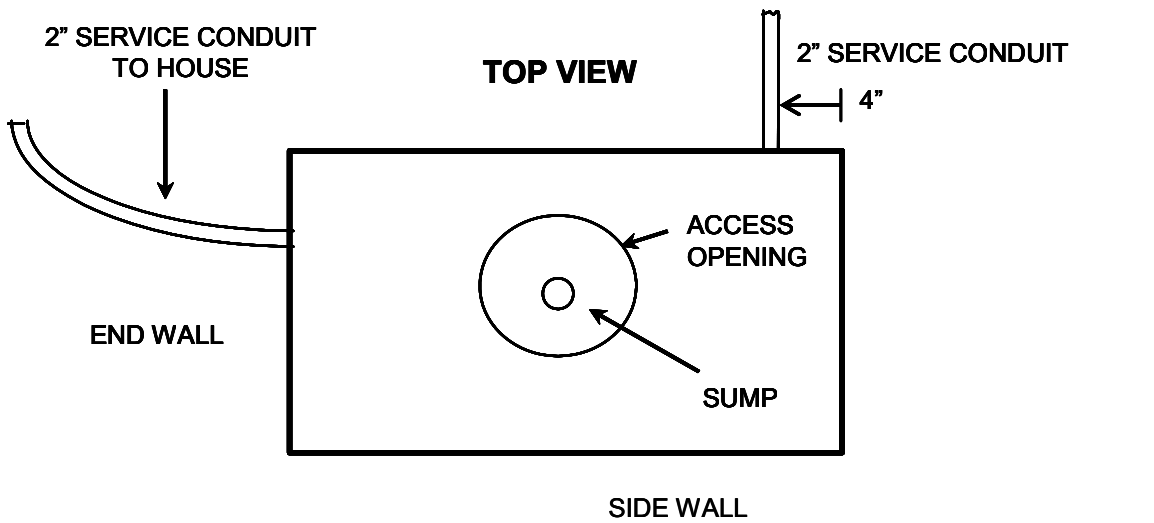

DO NOT INSTALL SERVICE CONDUITS INTO THE BOTTOM OF THE BOX

Bonding and Grounding

Bonding and grounding requirements must meet the National Electrical Code. Grounding Options are listed in the order of preference.

- 1. #10 copper ground wire to Electrical Power Service Grounding Electrode, Service Grounding Electrode Conductor or Service Panel**
- 2. #10 copper ground wire to a Concrete-Encased Electrode meeting the requirements of the NEC (UFER Ground)**
- 3. #10 copper ground wire to a Ground Ring meeting the requirements of the NEC or to the metal frame of the building which is effectively grounded.**

UNDERGROUND UTILITY ASSESSMENT DISTRICT No. 111

Private Conversion Checklist for Owner/Contractor

- _____ Wait for conversion letter from the City of Newport Beach to start work. (owner)
- _____ A pre-inspection checklist will be provided with conversion letter. (owner)
- _____ Retain an electrical contactor to perform underground utilities work. (owner)
- _____ Contractor to obtain SCE conduit map from Public Works Department prior to trenching and conduit installation. Contractor to contact SCE inspector for pre-construction meeting if needed. Enrique Cortez (714) 895-0448.
- _____ Apply and obtain approval for an electrical permit at City Building Department. The completed pre-inspection list must be presented. Should any portion of the work take place in the public right-of-way, an approved encroachment permit from the City Public Works Department must be obtained prior to starting work. (contractor)
- _____ Contractor to start work by opening trench, installing conduits, and upgrading the meter panel, as necessary.
- _____ Schedule a 2nd inspection with City Building Inspector to review trench, proximity of footing, conduits, and anything that is deemed necessary by the Building Inspector. This should be performed prior to closing the trench (contractor) .
- _____ Schedule a SCE “release inspection” with SCE inspector Enrique Cortez (714) 895-0448 to inspect trench, conduit material, pull rope, and all other designated SCE items. This inspection shall be completed prior to closing the trench. (contractor)
- _____ Schedule a “rough service release inspection” with City Building Inspector to inspect installed meter panel and grounding. This inspection shall be scheduled after the trench is backfilled and repaved. (contractor)
- _____ SCE will contact contractor to schedule a cut-over once 90 percent of the district has received City and SCE “release”. The contractor will need to meet with the SCE crew at the project site. (contractor)
- _____ Schedule a final inspection with City Building Inspector once all work is completed (contractor).

CONSTRUCTION NOTES:
Unless otherwise specified on the working drawing which forms a part of the specification, the Contractor/Developer shall furnish the following items at no cost to the Edison Company:

1. FOR GENERAL SPECIFICATIONS SEE UGS CI 001.
2. CONDUIT:
 - a. Minimum cover in street or parkway is 30" below gutter grade, unless noted otherwise.
 - b. Minimum cover on private property is 30" below finished grade, unless noted otherwise.
 - c. Contractor is to furnish and install approved conduit to Edison specifications per UGS CD 100.1, 110 AND 120.
 - d. For the type of conduit for this job, see UGS CD 110.1.
 - e. Install all risers per UGS CD 160, 161, 162 AND 170.
 - f. Cap all mainline conduits per UGS CD 148 and service conduits per UGS CD 150.
 - g. Install blank conduit plugs in all conduits terminating into Vaults, Manholes, PMH's, SCE's & all cap locations, per UGS CD 180.1 & UGS CD 180.2.
 - h. Install pull rope in all conduit runs. Pull rope to be at least 3/8" polypropylene rope, braided or twisted. For specifications, approved makes, and suppliers, see UGS CI 040.
 - i. All conduit must be manufactured with the approved mandrel UGS CD 197.

3. CONDUIT RADIUS REQUIREMENTS:
 - a. The minimum radius for bends are:
 - 36" for conduits 3" in diameter or smaller
 - 48" for conduits 4" and 5" in diameter
 - 60" for 6" diameter conduit.
 - b. The minimum radius for all sweeps of all mainline conduits is 12'-6" (unless noted otherwise).

4. EXCAVATION AND BACKFILL:
 - a. Work area shall be cleared and rough graded to within four inches of final grade prior to installation of Edison conduit or structures.
 - b. All excavations shall be in accordance with the California State Construction Safety Orders (when applicable), Edison specifications, and all governing local ordinances.
 - c. Each trench to be a uniform depth below final grade prior to installation of Edison conduit or structures.
 - d. Backfill shall be provided by the Contractor for all excavations and shall include crushed rock, concrete, and/or imported backfill, when required.
 - e. Backfill with a minimum of one sack per yard sand cement slurry around and over vaults and manholes per UGS CI 030, section 6.4 and around PMH's within one foot of finished grade, per UGS SS 590.1.
 - f. Backfill, per Edison specifications, shall immediately follow conduit or structure installation. At no time shall conduit be left exposed over 24 hours.
 - g. No rocks are allowed within 12 inches of direct-buried cables or any conduit without concrete encasement. Nothing is allowed of passing through a one-half inch mesh screen shall be considered to be "rock free". If existing backfill does not pass through a 1/2" screen, place imported sand 3" below and 12" above Edison cables. After this point, no rocks larger than 1/2" diameter are permitted.
 - h. All backfill shall be compacted to meet or exceed local ordinances or other requirements. It shall be placed in a manner that will not damage the conduit or substructure or allow future subsidence of the trench or structures.

5. PAVING:
 - a. Repaving, where required, shall be placed in such a manner that interference with traffic, including pedestrian traffic, will be kept to a minimum. The Contractor shall establish a program of repaving acceptable to the Municipality, County, or other authority having jurisdiction and which is acceptable to Edison.

6. STRUCTURES:
 - a. All substructures shall be constructed or installed to Edison specifications.
 - b. Install protection barriers per UGS MS 830 when required in areas exposed to traffic, per Edison Inspector.
 - c. All conduit lines and concrete floored substructures shall be water tight.
 - d. All grounding materials shall be furnished and installed by the Contractor.

7. RETAINING WALLS:
 - a. When required, retaining walls shall be provided by the Developer. Walls are required wherever grade rises more than 18 inches above the structure or 24" above the pad surface of a distance of 5 feet from the same, or in areas subject to erosion. Design and installation must comply with local building ordinances. Refer to Edison Inspector for typical space requirements.

8. PERMITS:
 - a. All permits necessary for excavation shall be provided by the Contractor/Developer.

9. ACCESS:
 - a. Heavy truck access shall be maintained to equipment locations. Structures must be clear of all appendages that would obstruct the loading or unloading of equipment.

10. SERVICES:
 - a. Meters and services shall comply with Edison Electrical Services Requirements.
 - b. Wiring must be in accordance with applicable local ordinances and approved by local Inspection Authorities.

11. LOCATION:
 - a. The location of excavations and structures for Edison shall be as shown on the working drawing. No deviation from the planned locations will be permitted unless approved by the Edison Inspector. See UGS CI 001, section 2.2.
 - b. Actual location of obstructions, storm drains, and/or other foreign utilities to be the responsibility of the Contractor. See UGS CI section 2.3.

12. CONTRACTOR TO VERIFY LOCATION AND WIDTH OF ALL SIDEWALKS AND DRIVEWAYS PRIOR TO STREET LIGHT INSTALLATION. See UGS CD 175.1, UGS CD 175.2 AND UGS CD 175.3.
13. SURVEY:
 - a. Surveying of street improvements, property corners, lot lines, finished grade, etc., necessary for the installation of underground facilities must be completed and markers or stakes placed prior to the start of the installation. In addition, Developer shall maintain the markers during the installation and inspection by Edison. Grade and property line stakes must show any offset measurements.

14. COORDINATION AND SUPERVISION:
 - a. The Developer shall provide supervision over and coordination among the various contractors working within the development in order to prevent damage to Edison facilities. He is responsible for the cost of repairs, replacement, relocation, or other corrections to Edison facilities made necessary by his failure to provide supervision or to otherwise comply with these specifications.

15. TELEPHONE AND OTHER UTILITY REQUIREMENTS:
 - a. The drawing prepared for this job may also cover the facilities to be installed for the telephone company and/or other utility. Any questions concerning details of their installation should be referred to the company concerned.

16. OWNERSHIP:
 - a. Developer is to deed to the Edison Company all structures shown herein except those shown as customer owned.

17. WARRANTIES:
 - a. Applicants expressly represent and warrant that all work performed and all material used in meeting Applicants' obligations herein are free from defects in workmanship and are in conformity with Southern California Edison Company's requirements. This warranty shall commence upon receipt by Applicants of Company's final acceptance and shall expire one year from that date. Applicants agree to promptly correct to the Company's satisfaction and that of any governmental agency having jurisdiction and of Applicant's expense any breach of this warranty which may become apparent through inspection or operation of underground electric system by Company during this warranty period.

18. INSPECTION:
 - a. Inspection is required during the construction period. A 48 hour advance notice of intent to start construction is required from the contractor to the Southern California Edison Company. Standards of Edison construction requirements are available upon request.

Duct and Structure Inspector: Phone: _____
Cabling Construction Coordinator: Phone: _____
005: Rev. 07/21/76

CONNECTING TO EXISTING SCE STRUCTURES

- Per SCE requirements, customers are not allowed to enter, intercept or tie-in to existing SCE structures, equipment or conductors. This work will only be performed by SCE. Contact the appropriate SCE Inspector to schedule an appointment. Customers may connect to an existing duct stub without a SCE Inspector present.
- Per CPUC/SCE's Rule 15 B.1.A and Rule 16 D.1.A., the customer will provide all necessary excavations (with the exception of excavation under pads and primary splice boxes), material (including conduit and structures) and encasement, to be utilized in the intercept/tie-in process.
- The customer must adhere to all applicable Cal-OSHA, local, city, state and federal regulations, (including, but not limited to, all necessary shoring and traffic control in place to protect the intercept/tie-in work by SCE's underground civil contractors(s)).
- Intercept/tie-in work must be coordinated with SCE's civil contractors through the Division Inspector/OCM to limit exposure of excavation(s). Customer is responsible for securing excavation(s).

DOB: 12/10/07

NOTE:
ALL ELECTRICAL DUCTS AND STRUCTURES WILL CONFORM TO GENERAL ORDER #128 (RULES FOR CONSTRUCTION OF UNDERGROUND ELECTRICAL SUPPLY AND COMMUNICATION PRESCRIBED BY THE PUBLIC UTILITIES COMMISSION OF THE STATE OF CALIFORNIA, JANUARY 2006).

WHERE CONDUITS ARE PICKED UP OR INTERCEPTED, CONDUIT SHALL BE MANDETTLED AND PULL ROPE INSTALLED FROM TERMINAL TO TERMINAL.

WARNING
THE EXCAVATOR MUST TAKE ALL STEPS NECESSARY TO AVOID CONTACT WITH UNDERGROUND FACILITIES WHICH MAY RESULT IN INJURY TO PERSONS OR DAMAGE TO FACILITIES IN THE AREA. THE INDICATED LOCATIONS OF EDISON UNDERGROUND FACILITIES, AS PROVIDED, ARE BELIEVED TO BE ACCURATE. HOWEVER, THE FINAL DETERMINATION OF EXACT LOCATIONS AND THE COST OF REPAIR TO DAMAGED FACILITIES IS THE RESPONSIBILITY OF THE EXCAVATOR.

Note: Per ESR 3, Section 15.5
Existing underground terminating pull box or switchboard pull section ampacity rating shall be equal to or greater than the ampacity rating of the total main switch capacity for which it is serving. Adding services exceeding the ampacity rating of a terminating pull box or switchboard pull section is not acceptable.

TIE-IN MADE INTO A SECONDARY HANDHOLE
If PVC conduit is used, riser bend installation may be made by the customer with prior SCE approval. Customer not to remove handhole cover. If metallic conduit is used or handhole cover needs to be removed, a SCE Qualified Person must be present.

CONDUIT RADIUS REQUIREMENTS:
A. The minimum radius for bends are:
36" for conduits 3" in diameter or smaller
48" for conduits 4" and 5" in diameter
60" for 6" diameter conduit.
B. The minimum radius for sweeps are:
36" for conduits 3" in diameter and larger,
unless otherwise noted.

UNDERGROUND SERVICE ALERT
Dial 811
For Underground Locating
2 Working Days Before You Dig

TYPICAL CONDUIT BANK SECTION
SEE UGS CD 120

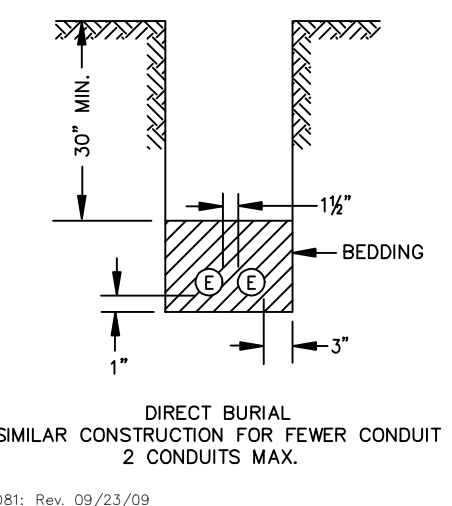

081: Rev. 09/23/09

TYPICAL CONDUIT SECTION JOINT WITH CATV & TELE
SEE UGS CD 120

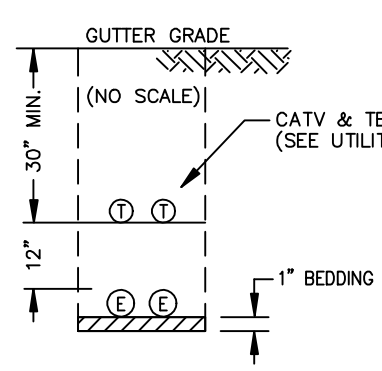

081: Rev. 09/23/09

RISER BEND INSTALLATION AT WALL OR PAD
SEE UGS CD 170

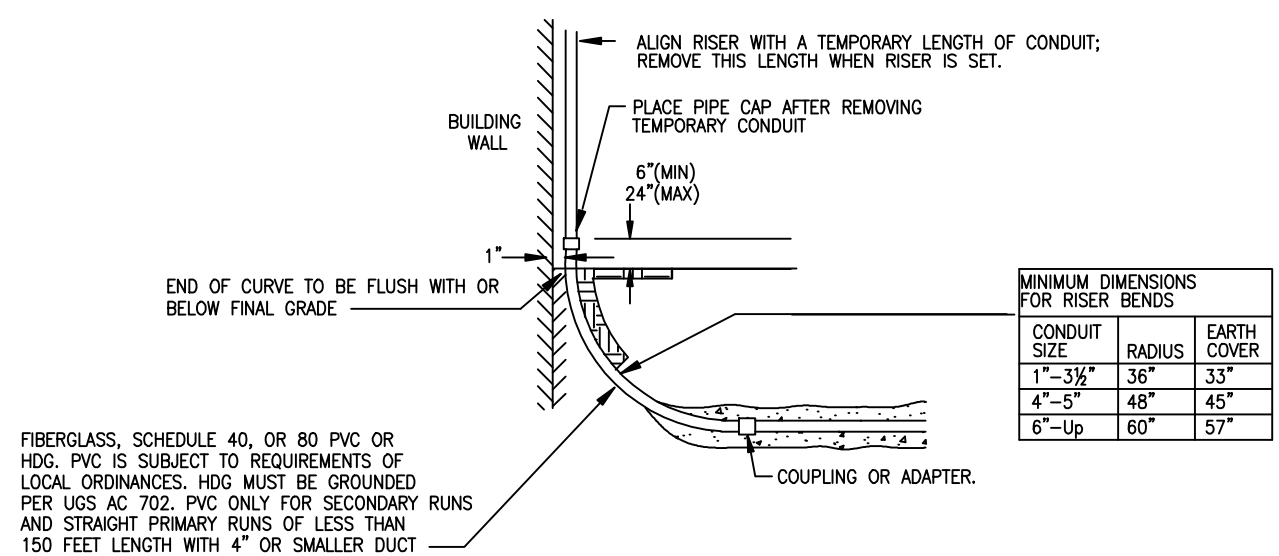

TYPICAL RISER AT BUILDING

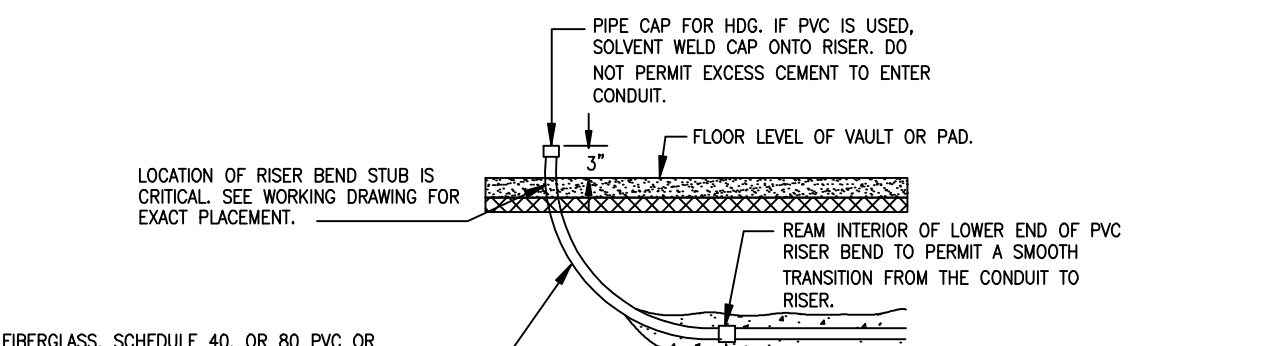

TYPICAL RISER AT VAULT OR PAD

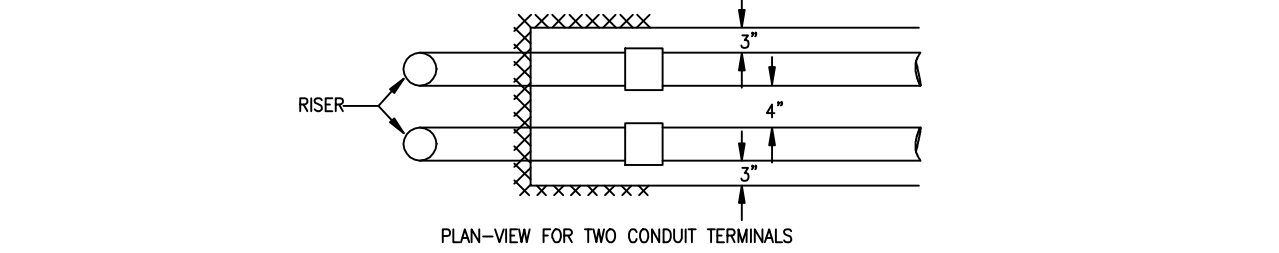

040: Rev. 01/10/72

TYPICAL HANDHOLE INSTALLATION
SEE UGS HP 205

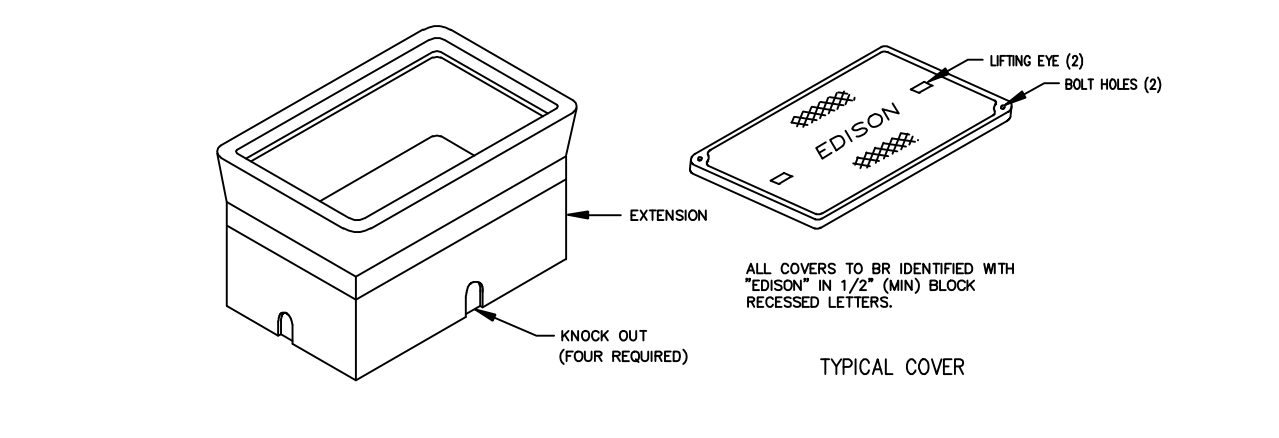

TYPICAL ASSEMBLY (WITHOUT COVER)

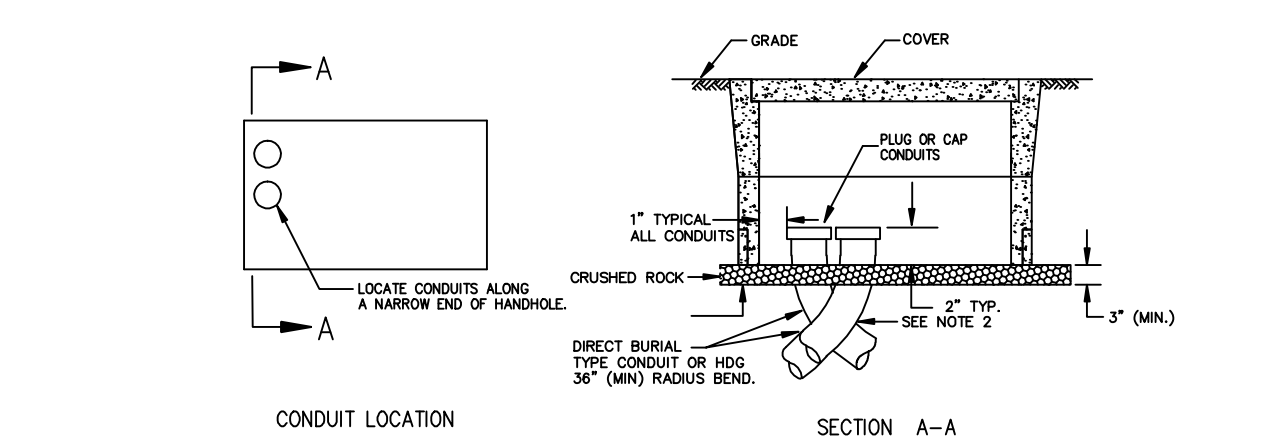

CONDUIT LOCATION

SECTION A-A

NOTES:

1. SEE UGS HP 200 FOR DIMENSIONS OF VARIOUS SIZE HANDHOLES AVAILABLE.
2. RADIUS ANGLE MAY BE REDUCED TO LESS THAN 90° PROVIDING THE PROJECTED CENTER LINE OF THE CONDUIT CLEARS HANDHOLE OPENING.
3. TWO HOLD-DOWN DEVICES TO BE SUPPLIED WITH EACH HANDHOLE.

075: Rev. 05/09/13

Table 3-5: Minimum Pull Box Dimensions

Service Ampacity (Amps)	W (See Note 5)			Y Depth (in)	X Height (in)
	3-Wire (in)	4-Wire (in)	(in)		
201-400	10-1/2	14	6	22	
401-800	16-1/2	22	11	26	
801-1,200	22-1/2	30	11	28	

Notes:

1. The above dimensions are for the case where the conduit enters the bottom of the pull box and all load conductors exit above the terminals. Where the service conduit enters from the side or back of the pull box, the "X" dimensions shall be taken from the closest portion of the conduit to the nearest termination box.
2. See ESR-6 for minimum termination clearances and for termination bus and bolt details.
3. Pull box covers shall be removable, sealable, provided with two lifting handles, and limited to a maximum size of nine-square feet in area.
4. Clear working space shall be maintained. Return flanges shall not intrude into the shaded space.
5. The "W" dimension is the minimum width of the pull box access opening.
6. Consult the local Service Planning Office for conduit requirements.
7. Terminating facilities shall be secured to prevent bus turning or misalignment when the cables are installed.

THREE, FOUR, FIVE, OR SIX-INCH FIBERGLASS RISER BENDS
SEE UGS CD 166

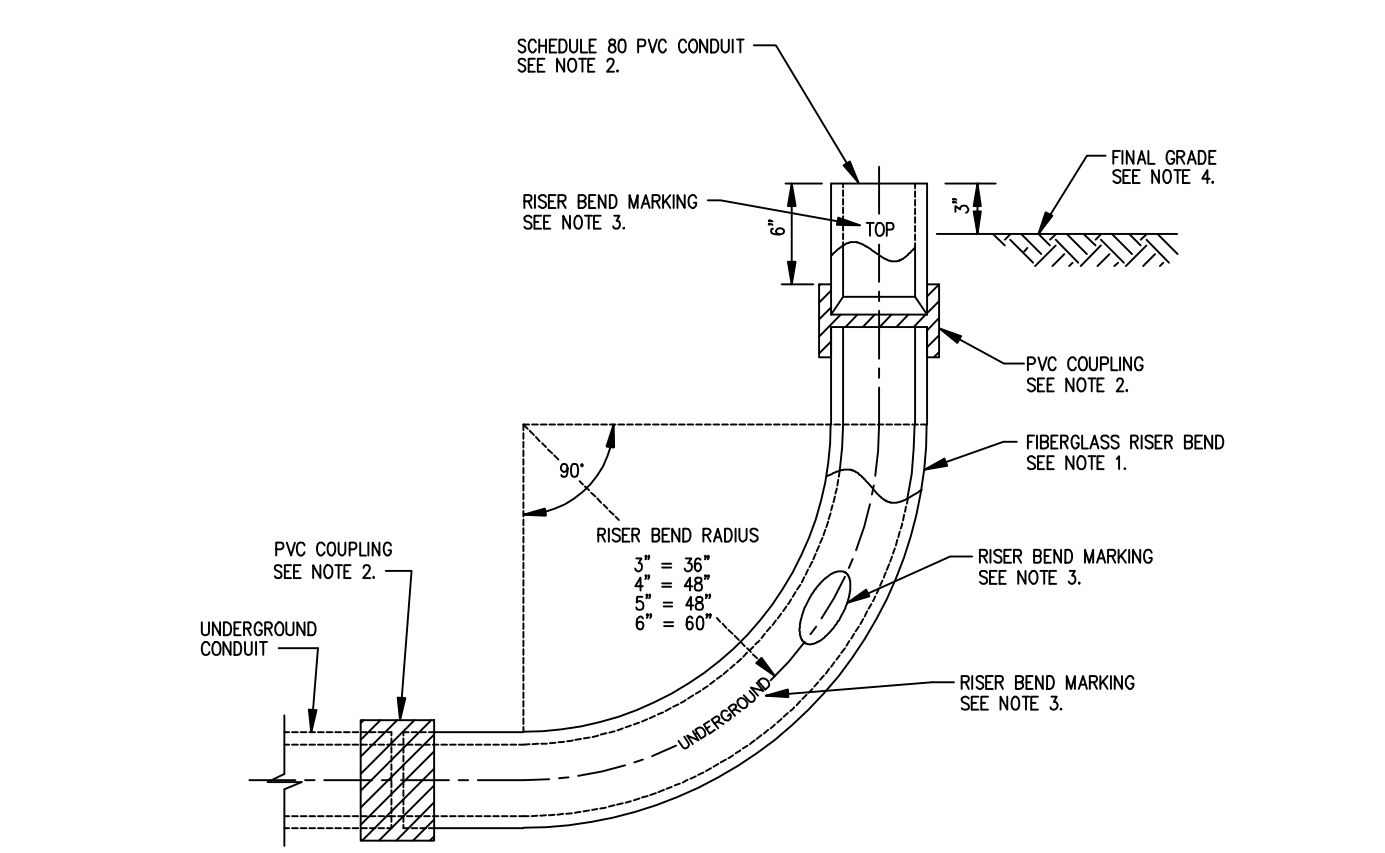

- NOTES:**
1. THE RISER BEND IS AVAILABLE IN THREE, FOUR, FIVE OR SIX-INCH. THE MAIN BODY OF THE BEND IS MANUFACTURED FROM FIBERGLASS MATERIAL AND IS MEDIUM GRAY IN COLOR.
 2. THE TOP AND BOTTOM OF RISER IS FURNISHED WITH PVC COUPLINGS PERMANENTLY EPOXY BONDED TO THE FIBERGLASS BEND. A SCHEDULE 80 PVC SIX-INCH LONG STUB-OUT IS SOLVENT WELDED INTO THE TOP PVC COUPLING.
 3. THE TOP SCHEDULE 80 PVC STUB OUT OF BEND IS STENCILED "TOP", AND BOTTOM OF BEND IS STENCILED "UNDERGROUND", MANUFACTURERS NAME, SIZE AND DATE (MONTH AND YEAR) WILL BE STENCILED ON THE CENTER OF THE RISER BEND.
 4. THE TOP SCHEDULE 80 PVC STUB OUT WILL BE PLACED THREE INCHES ABOVE FINAL GRADE. NO PORTION OF THE FIBERGLASS MATERIAL OF THE BEND WILL BE EXPOSED ABOVE THE FINISH GRADE.
 5. THE APPROVED MANUFACTURERS AND SUPPLIERS ARE:
 - A. MANUFACTURERS: FREE CONDUIT, SMITH PRODUCT COMPANY, AND CHAMPION FIBERGLASS, INC.
 - B. SUPPLIERS:
 - ARMSTRONG PRODUCTS COMPANY
13230 SATCOY STREET
NORTH HOLLYWOOD, CA 91605
 - CAL-DUCT, INC.
2522 LEE AVENUE
SOUTH EL MONTE, CA 91733
 - SAF-T-CO SUPPLY, INC.
1300 E. NORMANDY PLACE
SANTA ANA, CA 92705

REF: UGS CD 166
030: Rev. 02/10/71

WORKSPACE SURFACE-MOUNTED OR SEMI-FLUSH METER INSTALLATION
SEE ESR 5-25

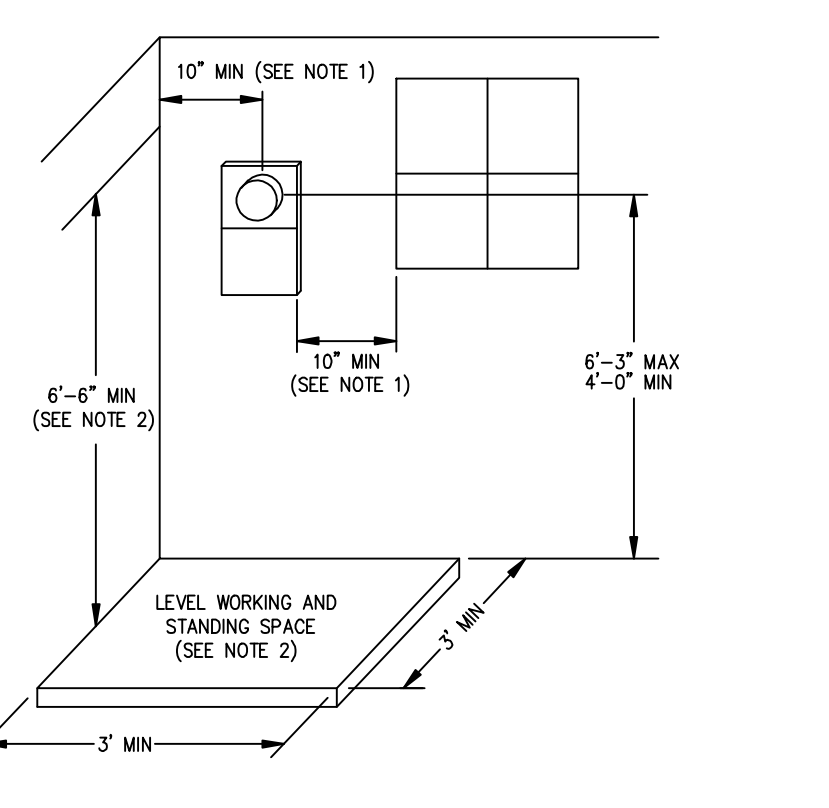

NOTES:

1. THE HORIZONTAL CLEARANCE FROM THE CENTERLINE OF THE METER TO THE NEAREST SIDE WALL OR OTHER OBSTRUCTION SHALL BE 10 INCHES MINIMUM. A HORIZONTAL CLEARANCE FROM THE EDGE OF THE METER PANEL TO THE EDGE OF A WINDOW OR DOORWAY (INCLUDING SLIDING GLASS DOORS) SHALL BE 10 INCHES MINIMUM. A GAS METER OR PLUMBING FIXTURE THAT DOES NOT PROVIDE MORE THAN 6 INCHES OUT FROM THE WALL, OR EXTEND LESS THAN 10 INCHES HORIZONTALLY FROM THE OUTSIDE EDGE OF THE METER PANEL, SHALL NOT BE CONSIDERED AN OBSTRUCTION. SEE ESR FIGURE 5-4 (PAGE 5-24)
2. A LEVEL WORKING AND STANDING SURFACE, CLEAR AND UNOBSTRUCTED, ENTIRELY ON THE PROPERTY OF THE CUSTOMER, SHALL BE PROVIDED. THE MINIMUM WIDTH OF THE WORKSPACE SHALL BE 36 INCHES OVERALL, BUT NEED NOT BE CENTERED BENEATH THE METER. THE MINIMUM DEPTH OF THE WORKSPACE SHALL BE 36 INCHES. WHERE METERS ARE ENCLOSED IN A CLOSET OR RECESS IN AN ENCLOSURE, THE DEPTH OF THE WORKSPACE IS MEASURED FROM THE OUTER FACE OF THE CLOSET OR RECESS. THE MINIMUM HEIGHT OF THE WORKSPACE SHALL BE 78 INCHES.

013: Rev. 04/22/15

SEPARATION OF METER ASSEMBLIES FOR ELECTRIC & GAS SERVICES
SEE ESR 5-24

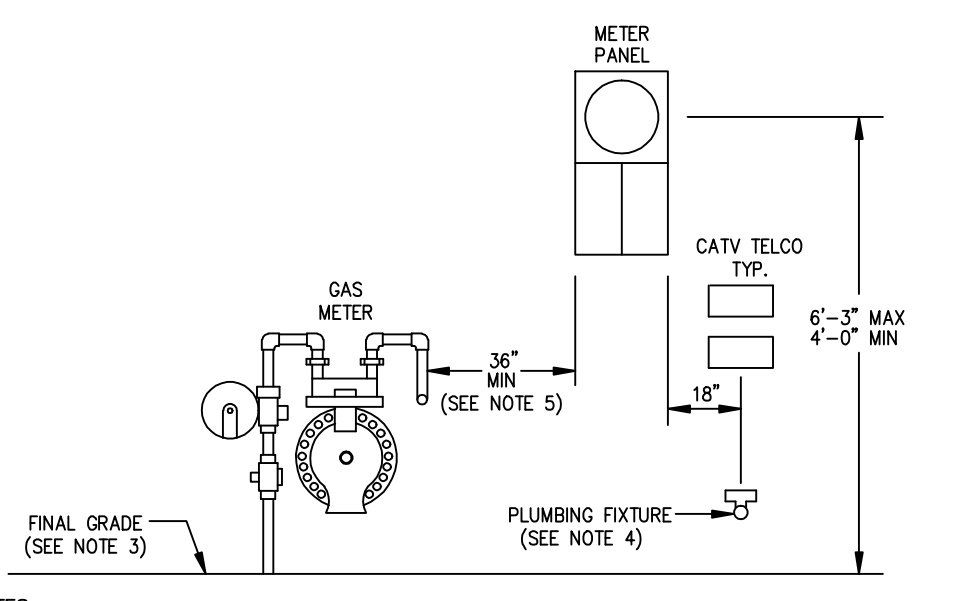
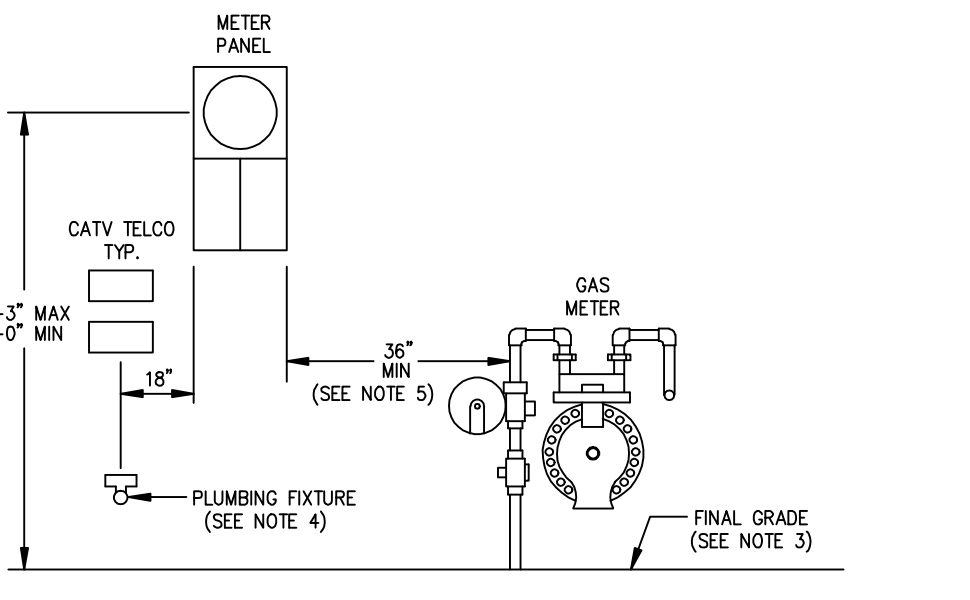

- NOTES:**
1. SIZE AND DIMENSION OF PANELS WILL VARY. DRAWINGS ARE NOT TO SCALE.
 2. THIS DRAWING PERTAINS TO BOTH OVERHEAD AND UNDERGROUND ELECTRIC SERVICE APPLICATIONS.
 3. MAINTAIN A 3 FOOT CLEAR LEVEL, AND UNOBSTRUCTED WORKSPACE IN FRONT OF ELECTRIC SERVICE EQUIPMENT.
 4. PLUMBING FIXTURES THAT EXTEND MORE THAN 6 INCHES OUT FROM WALL SURFACE MUST BE LOCATED 18 INCHES MINIMUM FROM THE OUTSIDE EDGE OF THE METER PANEL.
 5. FOR NEW CONSTRUCTION ONLY, DOES NOT APPLY FOR UPGRADES.

012: Rev. 04/10/16

Figure 3-13: Typical Service Conversion from Overhead to Underground

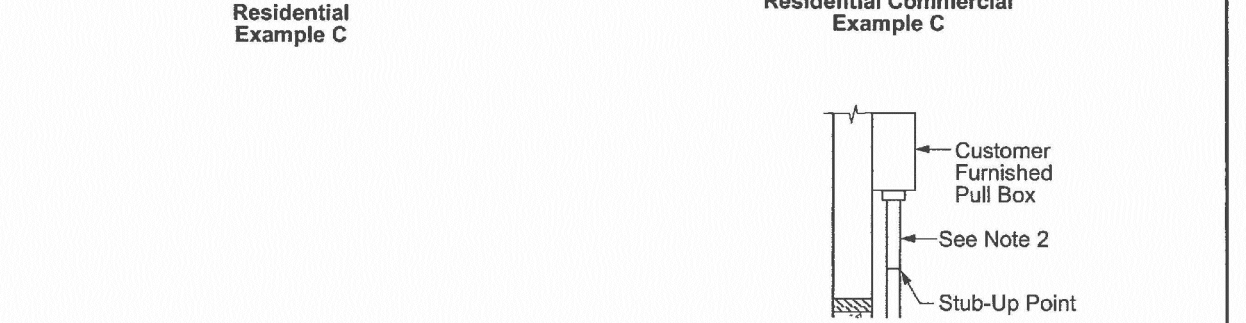
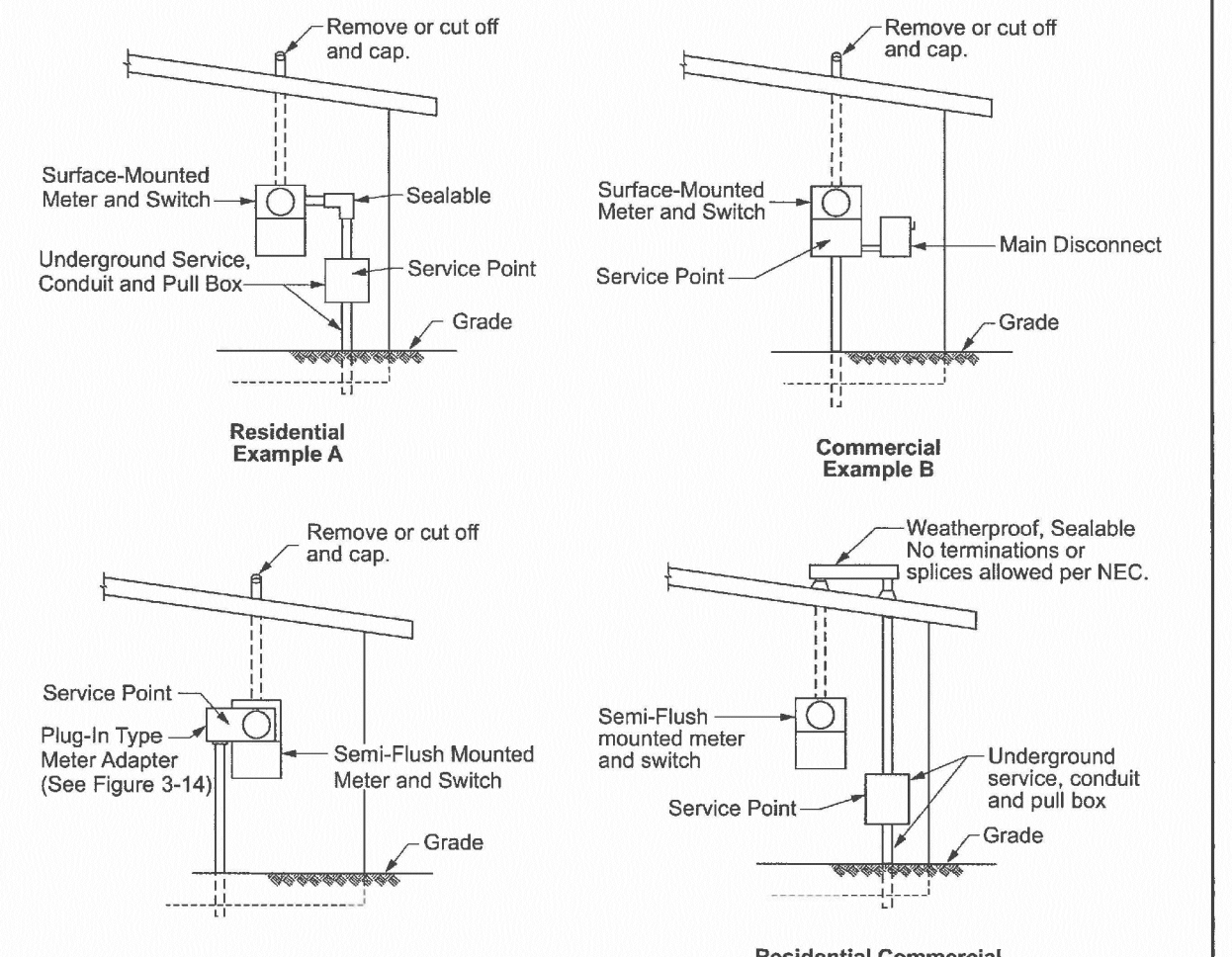

- Notes:**
1. Customer to furnish conduits pull boxes, adapters, gutters, trench, and backfill.
 2. Conduits may be stubbed-up by utility for customer pick-up.
 3. Exposed PVC conduit, where applicable to local inspection agency, shall be minimum Sch. 40. Where exposed to physical damage, install Sch. 80.
 4. Weatherhead-to-weatherhead conversion requires local city, county inspection, jurisdiction approval. Pull box shall be provided by the customer.

ESR-3	Underground Service Connections 0-600 V	EFFECTIVE DATE 4-27-2018
PAGE 3-32	Electrical Service Requirements SCE Public	APPROVED d/f

DISTRICT 33 - HUNTINGTON BEACH	PROJ. MGR. TODD PEARCE 714-973-5637	PLANNER DAVID A. VALDEZ 714-870-3171	SR NO. 2107170
FORUM N	TRUCK NO./P/E	INVENTORY MAP NO./THOMAS GUIDE OC 919-E2	DESIGN NO. 774269
CSD 140	BY-PASS EXISTING CHANGE TO	FLM CHECKED	E.P.R. NO. ASSOCIATED DESIG. NO. 774267
PRODUCT/SAP NO. TD1089243 (UG)	PRODUCT/SAP NO.	PRODUCT/SAP NO. TD1089241 (OH)	PROPOSED CONSTRUCTION (LOCATION) GUNTHER 12KV o/o CROWN SUB-RULE 20B ASSESSMENT DISTRICT NO. 117 NEWPORT BEACH
S. TODD 1/17/17	D. VALDEZ 12/12/16	TM/ASP 3/30/16	J.P. PAX 52810
DATE 03/30/16	CHECKED BY J. PINEDA	DRAWN BY A. SPAN	PAX #
APPROVED BY	DATE	CHECKED BY	DATE
Southern California Edison Company		1A	12
		JOB NO. 0774269	