



CITY OF NEWPORT BEACH

Fire Department

Fire Prevention Division

GUIDELINES AND STANDARDS

GUIDELINE C.01 – Emergency Fire Access: Roadways, Fire Lanes, Gates, and Barriers

C.01.1 PURPOSE

The purpose of this guideline is to provide information necessary to ensure that the design of emergency fire access meets the applicable regulations and standards. These provisions allow the emergency resources to respond to an incident in a safe and effective manner. The Newport Beach Fire Department, local law enforcement, and property owners are responsible for enforcing these requirements from the California Fire Code (CFC), California Vehicle Code (CVC), and the Newport Beach Municipal Code (NBMC).

C.01.2 SCOPE

In this guideline, the terms street, roadway, and road apply to all roads, streets, ways, lanes, alleys, avenues, fire lanes, etc. These outlined procedures are applicable to all emergency access roadways, whether public or private, unless otherwise noted. It includes the requirements for emergency access roadway design, signage, striping, and alternative surfaces, plus requirements and provisions for enforcement.

C.01.3 PROCEDURE

FIRE APPARATUS ACCESS ROADS AND FIRE LANES

1. Approved fire apparatus access roads shall be provided for every facility, building or portion of a building hereafter constructed or moved into or within the jurisdiction. The fire apparatus road shall comply with the requirements of this guideline and shall extend to within 150 feet of all the facility and all portions of the exterior walls of the first story of the building as measured by an approved route around the exterior of the building or facility.
 - More than one road may be required when it is determined that access by a single road may be impaired by vehicle congestion, condition or terrain, weather conditions which could result in dangerous situations or other factors that could limit access.

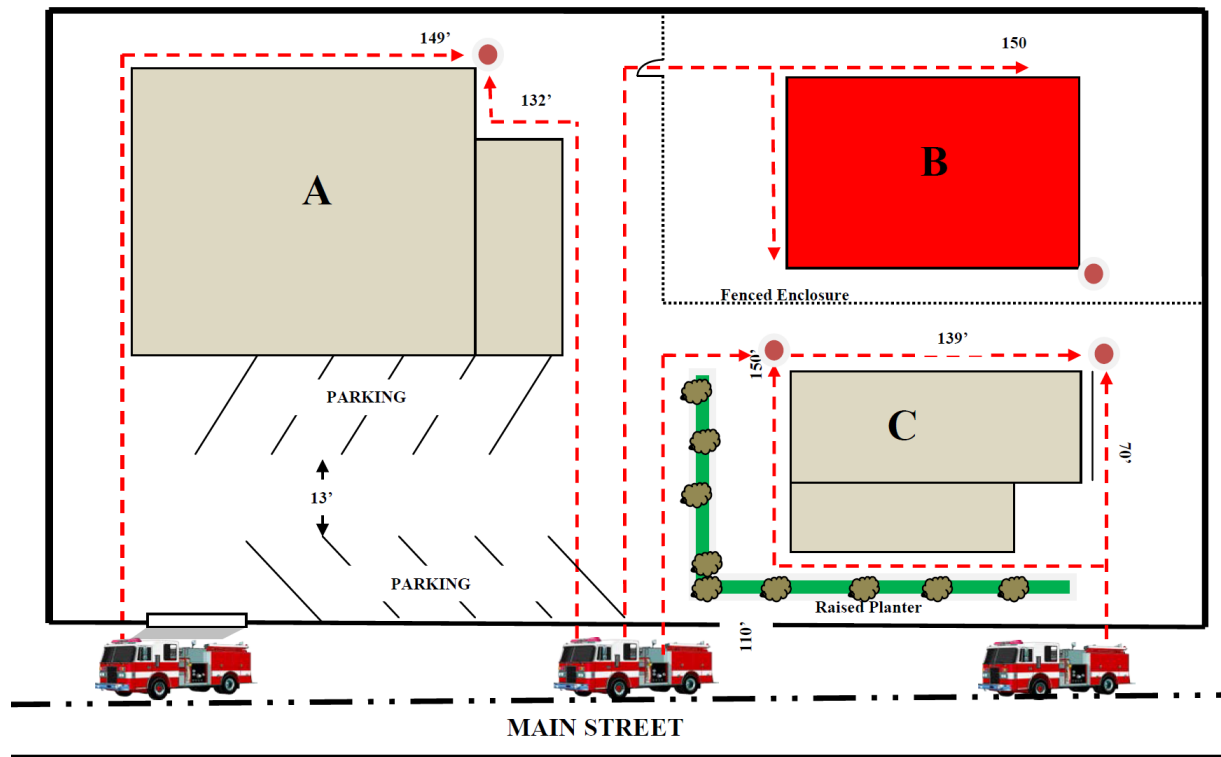

Legend:

- Denotes furthest point on the exterior of the building as measured along the path of firefighter travel around the exterior of the building.

Example: Assume that the parking lot is not accessible to fire apparatus due to the turning radii and fire lane widths less than the required minimums.

- All portions of building “A” are within 150’ of the public road as measured along the path of firefighter travel.
- Building “B” is not accessible; the presence of a fence enclosure forces firefighters to backtrack once they pass through the gate, increasing their travel distance beyond 150’.
 - On-site fire apparatus access roadways or a change in the location of the gate would be necessary to provide access to Building “B.”
- Building “C” is also accessible despite the obstruction posed by the raised planter.

Note: It may be necessary to enter the property even though this example is for inaccessibility. Situations such as high traffic flow of the facing street, may warrant staging of emergency responder equipment onsite to provide added safety off the roadway. Additional measures may be necessary for access as deemed by the Fire Code Official.

- When required by the Fire Code Official, approved signage or other approved notices shall be provided and maintained for emergency access roads to identify such roads and prohibit obstruction thereof or both. Signs or notices shall be always maintained in a clean and legible condition and to be replaced or repaired when necessary to provide adequate visibility.
2. Widths are to be measured from top of the face of the curb on streets with curb and gutter, from flowline-to-flowline on streets with rolled curbs. Flowline is the lowest continuous elevation of a rolled street curb defined by the path traced by a particle in a moving body of water at the bottom of the rolled curb.

These dimensions are for straight roadways only. Apparatus turning radius requirements must also be met. Details are located on pages 5-7.

- Fire Access – The minimum street width shall be 20 feet, with no parking on either side. The width shall be increased to 26 feet within 30 feet of a hydrant, no vehicle parking allowed. Parking on one side is permitted for streets that are a minimum of 28 feet wide. Parking on both sides of a street is permitted for streets that are a minimum of 36 feet wide.
- [City of Newport Beach Council Policy Manual L-4 Private Streets](#) – The minimum width of the street shall be 32 feet, with parking allowed on one side. The minimum width for parking on two sides of the street is 36 feet.
- Fire Access Roadway – The minimum width of the street shall be 36 feet, with parking allowed on both sides.

Fire apparatus access roads shall have an unobstructed vertical clearance of not less than 13 feet 6 inches.

3. Roads must be constructed of a material that provides an all-weather driving surface and capable of supporting 72,000 pounds-imposed loads for fire apparatus and truck outrigger loads of 75 pounds per square inch over a two-foot area. Calculations stamped and signed by a Registered Professional Engineer (RPE) shall certify that the proposed surface meets the criteria of an all-weather driving surface and can withstand the weight of 72,000 pounds.
4. The gradient for access roads shall not exceed 10%.

5. Any obstruction in required fire access roadways such as speed humps or other traffic calming measures, when approved by the Fire Code Official, shall be in accordance with the [City of Newport Beach Council Policy Manual L-26 Traffic Management Policy](#).
6. The inside turning radius for an access road shall be 20 feet or greater. The outside turning radius shall be a minimum of 40 feet. Cul-de-sacs with center obstruction (islands) will require a larger turning radius as approved by the fire code official.
7. Dead end fire apparatus access roads more than 150 feet in length shall be provided with an approved cul-de-sac for turning around fire apparatus without backing up. Turnarounds shall meet the turning radius requirements identified above as well as local standards for cul-de-sac design. The minimum cul-de-sac radius is 40 feet without parking.
8. Approach to fire access roads shall be constructed in accordance with the [Design Criteria & Standard Drawings for Public Works Construction](#).
9. The design shall incorporate a curb cut or rolled curb at both the entrance and exit points that delineates entry onto the alternative surface. The curb cut or rolled curb must be indicated on the plan and must meet Public Works [STD 182 Standard Curb Sections](#) or [STD 183 Type F Rolled Curbs](#).

FIRE APPARATUS ACCESS ROAD WIDTHS



Fire Access

Fire access width shall be 20', with no parking on either side.

Fire lane signage is required to be posted on both sides.

*The width shall be increased to 26' within 30' of a hydrant, no vehicle parking allowed.

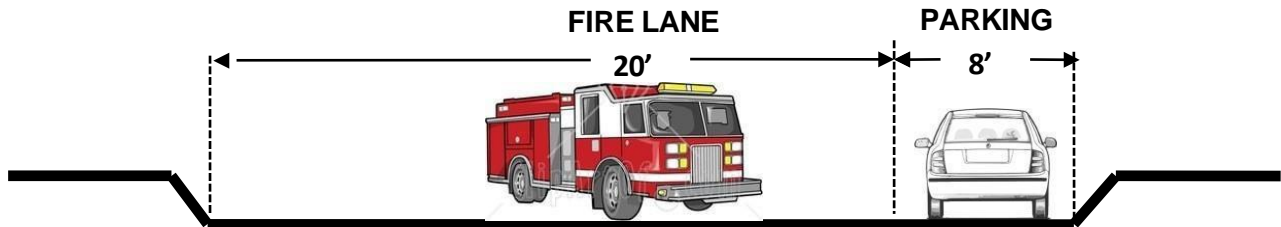

Fire Access - Circulation

Fire access shall be 20' with 8' for parking on one side.

Roadway is required to be posted as a fire lane on at least one side.



Private Streets per Council Policy L-4

Roadway at least 32' but less than 36'

Roadway is required to be posted as a fire lane on at least one side.



Roadway 36' or wider

Parking is permitted on both sides of the roadway.

HAMMERHEAD TURNAROUND, "T" TURNAROUND, and "Y" TURNAROUND

This is an alternative to cul-de-sac turn around. Slopes within the turnaround cannot exceed 10 percent.

HAMMERHEAD TURNAROUND

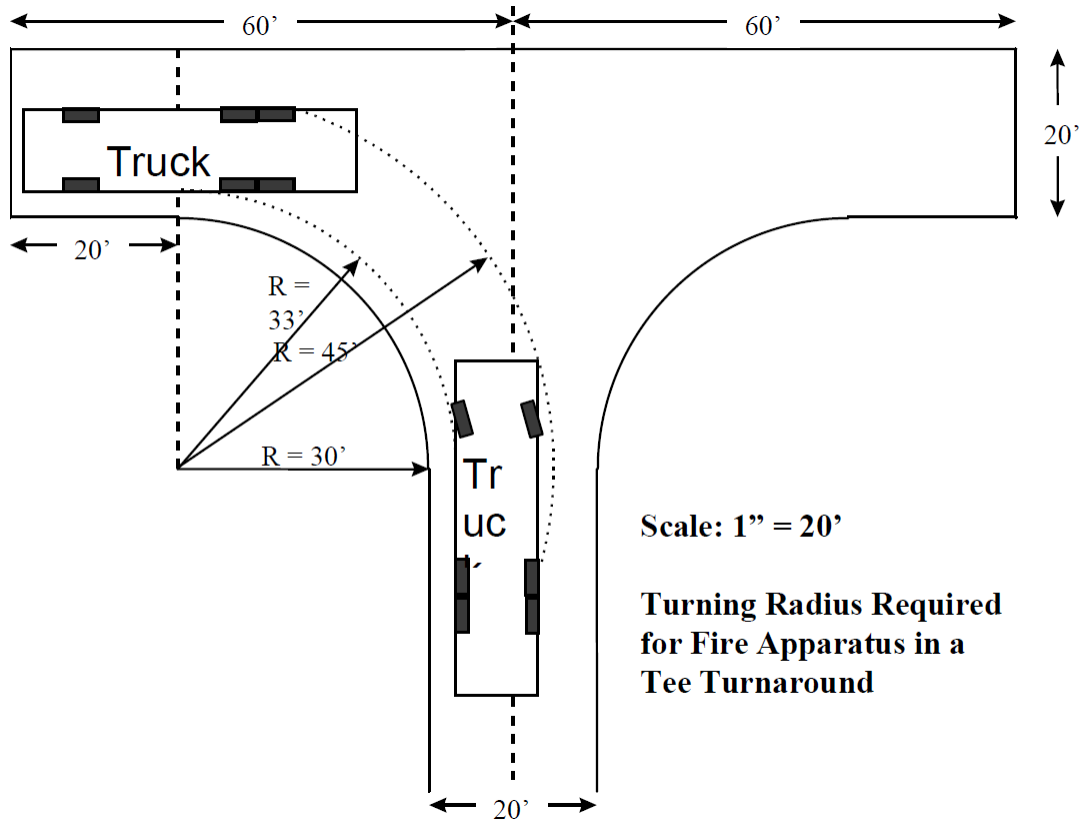

"T" TURNAROUND

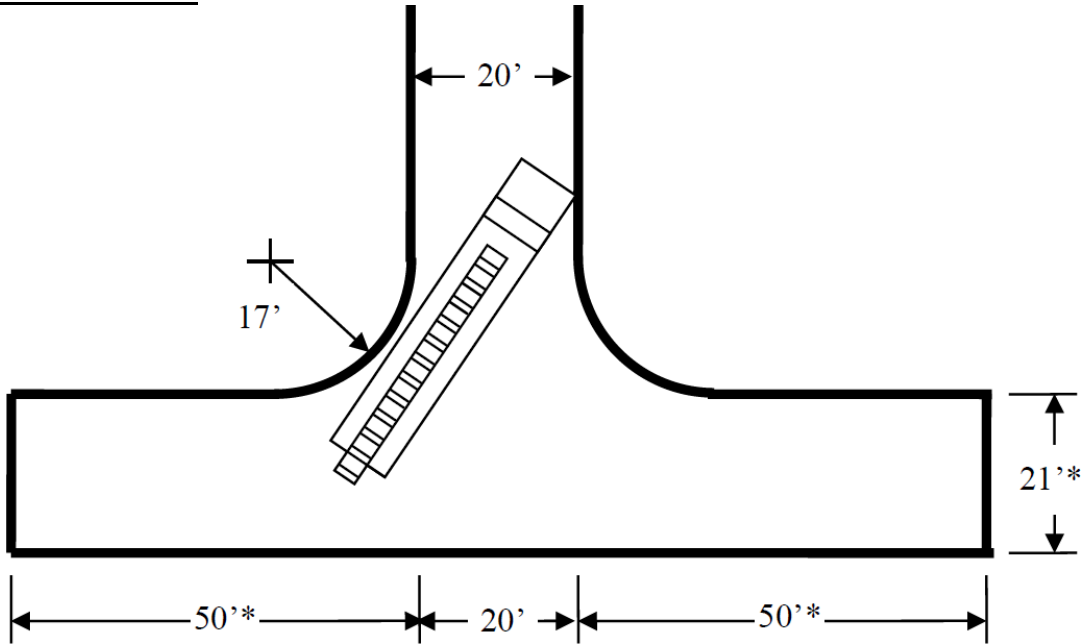

"Y" TURNAROUND

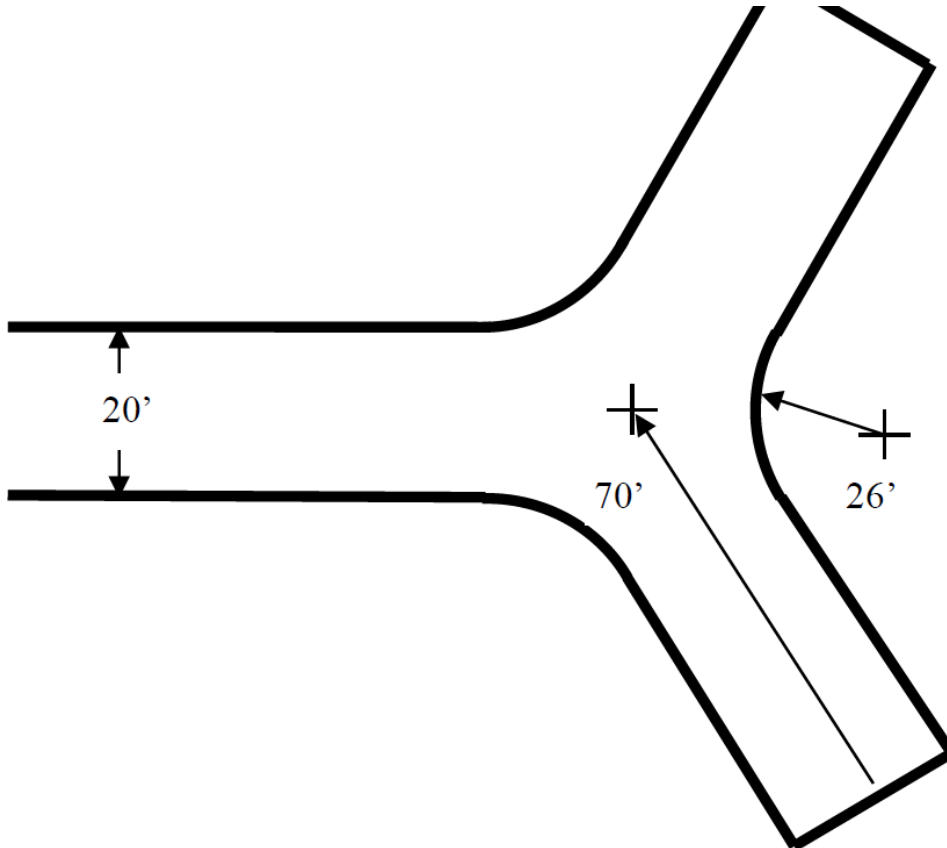

ANGLE OF APPROACH AND DEPARTURE

The angle of approach or departure affects the road clearance of vehicles when going over short steep grades such as in a driveway entrance, crossing a high crowned road at right angles, or in off-road service. Too low an angle of approach or departure will result in scraping the apparatus body. In those cases where equipment is stored below the body, the angle of approach or departure must be measured to a line below the equipment.

- NFPA 1901: Standard for Automotive Fire Apparatus – This standard specifies the minimum requirements for new automotive fire apparatus.
- Angle of approach – The smallest angle made between the road surface and a line drawn from the front point of ground contact of the front tire to any projection of the apparatus in front of the front axle.
- The angle of approach and the angle of departure of at least 8 degrees shall be maintained at the front and rear of the vehicle when it is normally loaded.
- The angle of departure and angle of approach of a fire access roadway shall not exceed 7 degrees (or 12 %) or as approved by the Fire Code Official.

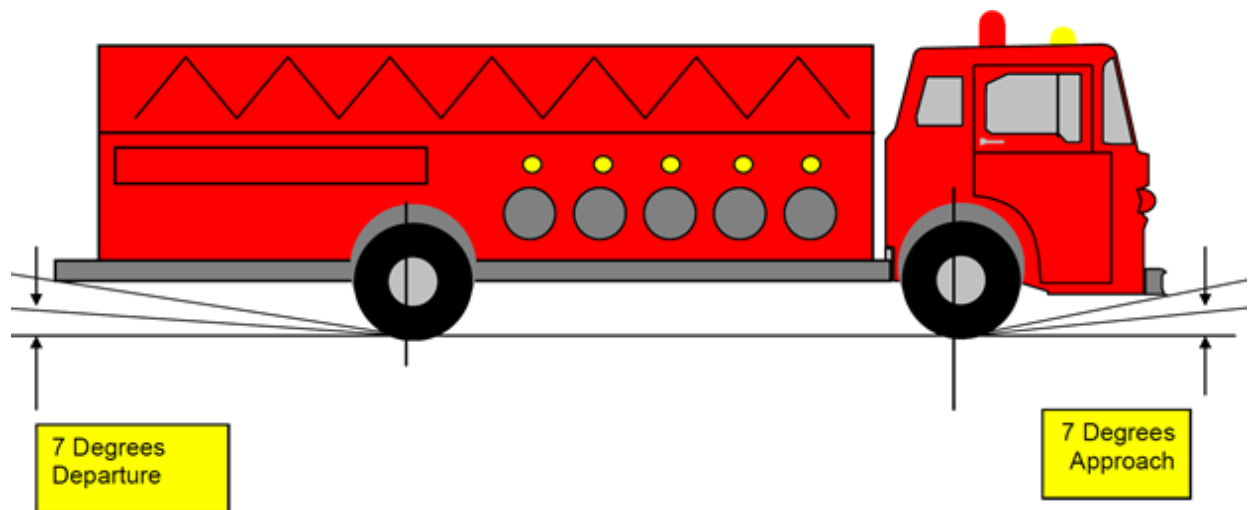

ENGINEERED ALTERNATIVE SURFACE FIRE ACCESS ROADS

Alternatives to paved surface fire access roads may only be used when approved by the Fire Code Official. The following standards shall apply to the use of engineered alternatives to surface paved fire access roads.

1. Calculations and a statement stamped and signed by a Registered Professional Engineer (RPE) shall certify that the proposed alternative surface and its substrate meet the criteria for an all-weather driving surface as specified by the product manufacturer. The engineer shall also certify that the alternative surface can withstand the weight requirements under all weather conditions as specified in this guideline, Section C.01.3 (3).
2. The manufacturer's specification for the product must indicate that the product is approved for the application or consistent with the manufacturer's recommendations. Manufacturer's specifications, including details for the required substrate must be included with the plan.
3. Alternative surface fire access roads may not exceed one hundred and fifty feet (150 feet) in length, from beginning to end, unless approved by the Fire Code Official. The road shall conform to the width requirements described in this guideline, Section C.01.3 (2).
4. Alternative surfaces shall only be installed on slopes of one degree (1.75% grade) or less unless specified for steeper grade by the manufacturer and approved by the Fire Code Official.
5. A minimum of four-inch-wide concrete strip shall delineate the alternative surface on both sides of the lane. Alternatives to concrete must be approved by the Fire Code Official. Strip delineations shall be indicated on the plans.
6. The following sentence shall be placed on the plan: "Final approval is subject to actual field acceptance testing utilizing fire department apparatus."
7. A clause requiring permanence, maintenance, and upkeep of the alternative surface shall be included in the property's CC&R, deed, and/or similar document. The document shall be submitted with the plans.

FIRE APPARATUS ACCESS GATES AND BARRIERS

1. Vehicle access gates or barriers installed across streets shall be in accordance with this guideline and the CFC and NBMC. Three site plans are required for gate/barrier plan review and approval. Plans shall indicate measurements, location, type of gate/barrier, and type of locking device, approved opening devices, and gate swing direction.
2. The minimum width of any gate or opening required as a point of access shall not be less than 14 feet unobstructed width. The minimum width may be increased depending on the length of the approach.
3. All emergency vehicle access gates, private gated communities, chains across fire lanes, and gates that provide access to the beach and/or wildland areas, shall have a lock approved by the Fire Prevention Division. Where gates are electrically operated, an approved key switch and an approved remote opening device shall be installed and maintained operational at all times, or the gate shall be locked in the open position until operational.

CONSTRUCTION AND DEMOLITION ACCESS

Approved vehicle access for firefighting shall be provided to all construction or demolition sites. Vehicle access shall be provided to within 100 feet of temporary or permanent fire department connections. Vehicle access shall be provided by either temporary or permanent roads capable of supporting vehicle loading under all weather conditions. Vehicle access shall be maintained until permanent fire apparatus access roads are available.



LADDER TRUCK ACCESS

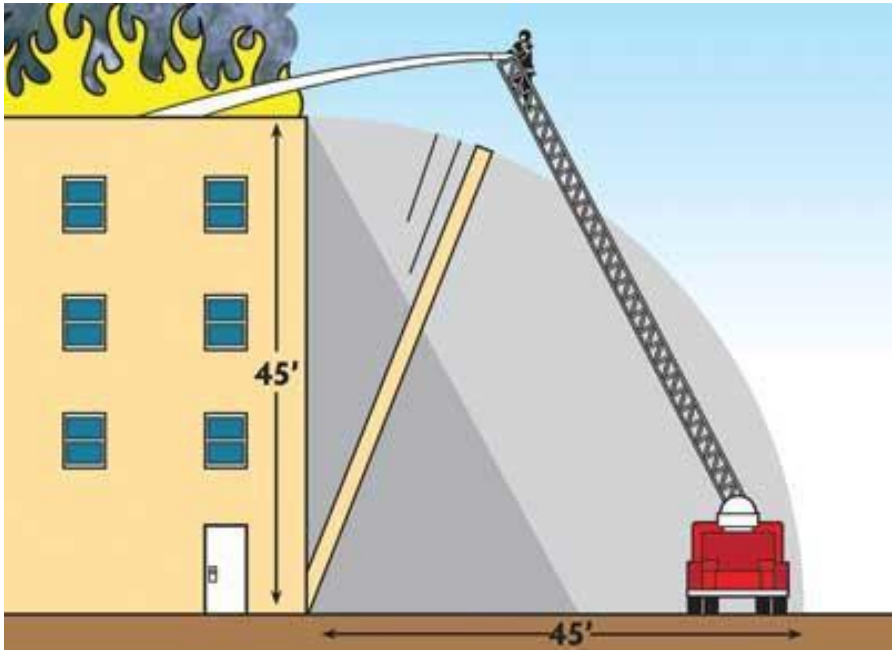

LOAD CAPACITIES

The following load capacities shall be established with the stabilizers at full horizontal extension and placed in the down position to level the truck and to relieve the weight from the tires and axles. Capacities shall be based upon full extension and 360-degree rotation.

50 MPH WIND CONDITIONS/WATERWAY DRY

Degrees of Elevation	-8 to 9	10 to 19	20 to 29	30 to 39	40 to 49	50 to 59	60 to 69	70 to 75
Egress					500	500	500	500
Fly					250	250	750	1000
Upper Mid					250	500	1000	1000
Lower Mid					500	750	1000	1000
Base					750	1000	1000	1000

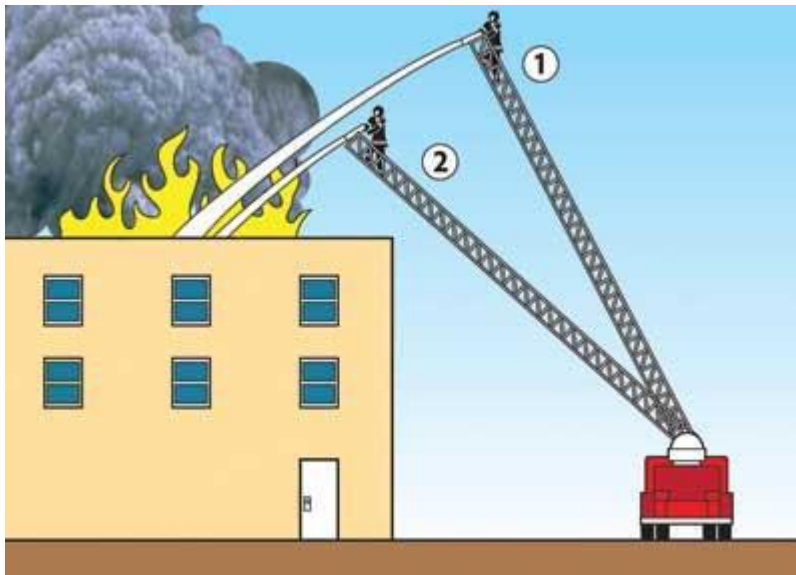

Aerial positioning is dependent on many factors such as access, type of structure, primary objectives, hazards, obstructions, and most importantly the reach of the aerial ladder. This determination of positioning will be subject to a case-by-case basis but at a minimum the quint or ladder truck has a minimum of ② 15-feet and a maximum of ① 35-feet from the building. This gives the ladder the greatest load capability when maintained between 40 to 75 degrees.

PYTHAGOREAN THEOREM

To understand the importance of reach and height of a ladder, consider a right triangle. The length of the hypotenuse (longest side of a triangle) equals the square root of the sum of the two shorter sides. When an aerial ladder is elevated, the ladder is the hypotenuse of a triangle of which the ground and the vertical wall of the building at the point to be reached represent the two shorter sides. Thus, the distance a given length of ladder will reach depends upon the two shorter sides of the triangle.

The square of the length of the hypotenuse of a right triangle equals the sum of the squares of the lengths of the two shorter sides. $A^2 + B^2 = C^2$

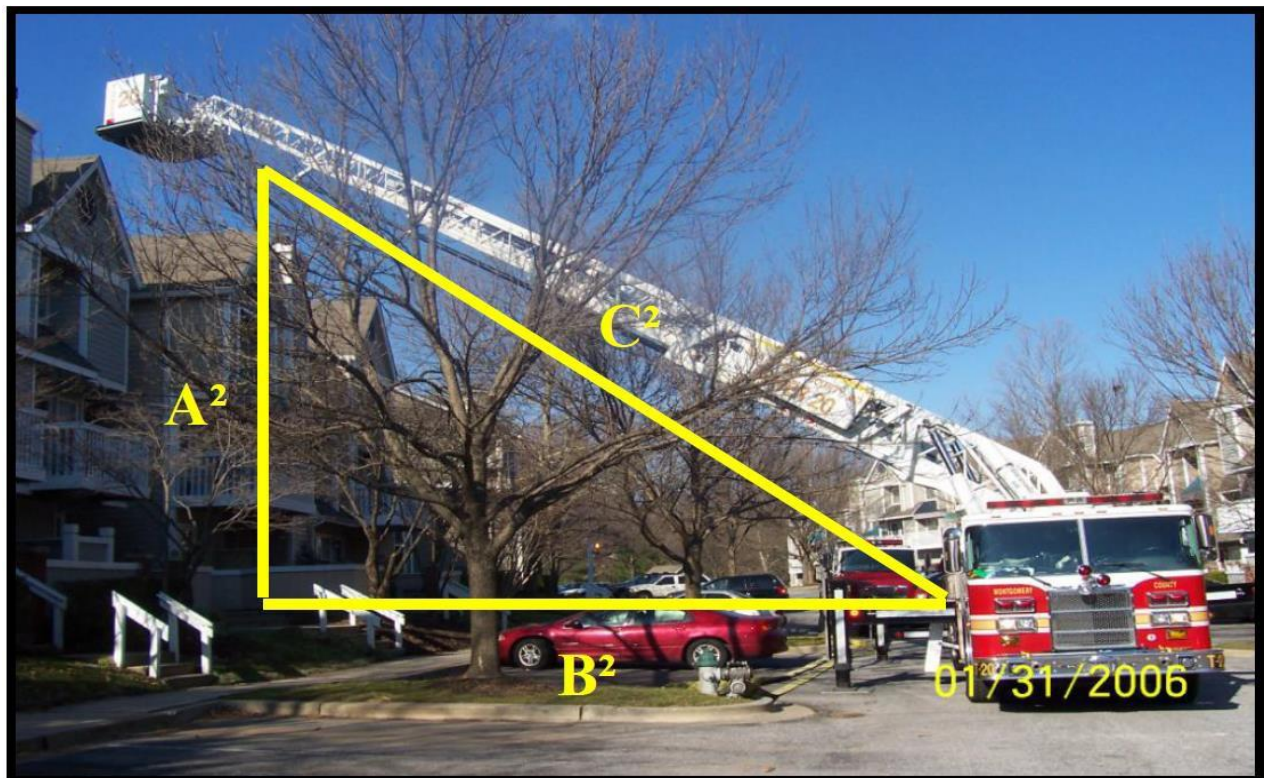

In this illustration, “A” equals the height of the building (use 12 feet per floor for commercial and multi-family structures). “B” equals the distance from the building to the turntable. “C” is the required distance to reach the building.

Example 1

$$A^2 (36 \times 36) + B^2 (50 \times 50) = C^2$$

$$1296 + 2500 = 3796$$

(Calculate the square root of C^2)

The square root of 3796 is 62.

In this example the required reach is 62 feet or 54 degrees.

Example 2

$$A^2 (75 \times 75) + B^2 (25 \times 25) = C^2$$

$$5625 + 625 = 6250$$

(Calculate the square root of C^2)

The square root of 6250 is 79.

In this example the required reach is 79 feet or 18 degrees.

NEWPORT BEACH FIRE DEPARTMENT TRUCK SPECIFICATIONS



100 FOOT STEEL AERIAL LADDER LOAD CHART 500# RATED TIP CAPACITY

WATERWAY DRY 50 MPH Wind Condition								
	Aerial Elevation							
	-8° to 9°	10° to 19°	20° to 29°	30° to 39°	40° to 49°	50° to 59°	60° to 69°	70° to 75°
Egress	500#	500#	500#	500#	500#	500#	500#	500#
Fly	-	-	-	-	250#	250#	750#	1000#
Upper Mid	-	-	-	250#	250#	500#	1000#	1000#
Lower Mid	-	-	250#	250#	500#	750#	1000#	1000#
Base	-	250#	500#	500#	750#	1000#	1000#	1000#

WATERWAY CHARGED 50 MPH Wind Condition								
	Aerial Elevation							
	-8° to 9°	10° to 19°	20° to 29°	30° to 39°	40° to 49°	50° to 59°	60° to 69°	70° to 75°
Egress	500#	500#	500#	500#	500#	500#	500#	500#
Fly	-	-	-	-	-	250#	500#	750#
Upper Mid	-	-	-	-	250#	500#	750#	1000#
Lower Mid	-	-	-	250#	500#	750#	1000#	1000#
Base	-	-	250#	500#	750#	1000#	1000#	1000#

Reduced loads at the tip can be redistributed in 250# increments to the fly section, upper mid section, lower mid section or base section as needed.

Capacities are based on the following conditions:

- * Apparatus is set up according to the operator's manual and leveled to within safe operating limits.
- * The ladder is fully extended and unsupported, 360° continuous rotation.
- * For icing conditions, refer to the operator's manual.

Rated vertical height: 100 feet

Rated horizontal reach at: 0° = 95 feet-1 inch
 45° = 66 feet-9 inches
 75° = 23 feet-11 inches

Unlimited monitor nozzle positions
while flowing up to 1000 GPM

P/N 2354863